



Kawakawa Bay 3 Karaka Road

Beach escape with many options

Beach escape with many options

- Four bedrooms plus study or home office
- Two generous living spaces for everyone
- Two stylish kitchens with breakfast bars
- Two bathrooms with underfloor heating
- Seamless indoor/outdoor flow
- Generous double garaging for vehicles
- Room for the boat, jet skis and kayaks
- Multiple outdoor Alfresco areas, two undercover
- Provides self-contained accommodation
- Solar panels, water bore
- Two 25,000 litre water tanks to utilise
- Two laundries, one at each end of the home

A rare opportunity and not one to miss



Within minutes you are on the water with your boat or jet ski

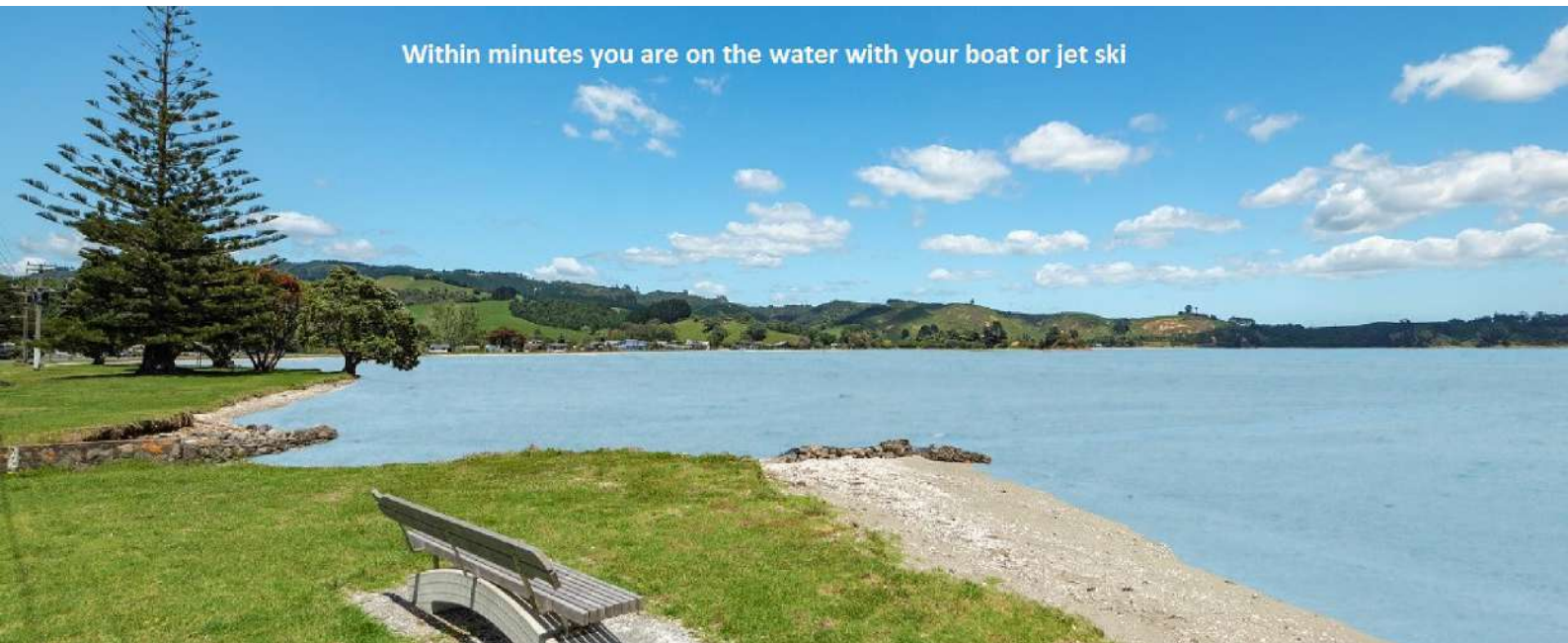

Property Information

4 2 2 2 4

Legal Description	NA93C/461, Part Lot 19 DP 23811
Rates	\$2,951.58
Capital Valuation	\$955,000
Land Area	950m ² (more or less)
Tenure	Fee Simple

Chattels

Fixed floor coverings, Blinds, Curtains, Light fittings, Auto Garage Door, Auto Garage Door Remotes x2, Ceiling Fans x3, Clothesline x2, Dishwasher x2, Heated Towel Rails x2, Hob - Induction x2, Light Fittings, Rangehood x2, Ovens x2, Wash machine taps, Waste Disposal x2, Wood Burner, Solar Power x16 Panels, 25,000 Ltr Water Tanks x2, Water Bore

Terms of Supply

Property Address: 3 Karaka Road, Kawakawa Bay, Auckland

Information Supplied: Land Title Document / Plans / REAA Sale and Purchase Guide / Rental Appraisal

By accepting the information above from Bayleys Real Estate Ltd, or an authorised licensee in conjunction with Bayleys Real Estate Ltd, I acknowledge I have read, understood and accepted the terms on which the information is made available.

Terms upon which the information is supplied:

1. Where information is supplied by Bayleys Real Estate Ltd to customers, the information is information in the possession of the Vendor(s) that the Vendor(s) are making available to the customer without endorsement
2. No representation is made by Bayleys Real Estate Ltd or by the Vendor(s) as to the accuracy, or to the reliability, of any information made available to the customers.
3. The customer will seek such advice and explanation the customer may require from an independent specialist of their choosing.
4. Should the purchaser decide not to obtain their own specialist advice they are deemed to have satisfied themselves on all aspects of the property and are buying solely in reliance on their own judgment and contrary to the recommendation of Bayleys Real Estate Ltd or its agents.

BUILDING INSPECTIONS

Purchasers are advised to secure their own Building Inspection Report regardless of construction type, to ensure that they are fully informed as to the standard of the property they intend to invest in.

QUERIES OR REQUESTS

It will be a pleasure to assist you further should you require any additional information, or have any queries regarding the property or content of this booklet, please do not hesitate to contact us.



**COMPUTER FREEHOLD REGISTER
UNDER LAND TRANSFER ACT 1952**



Search Copy

R. W. Muir
Registrar-General
of Land

Identifier NA93C/461
Land Registration District North Auckland
Date Issued 24 March 1994

Prior References

NA663/85

Estate Fee Simple
Area 950 square metres more or less
Legal Description Part Lot 13 Deposited Plan 23811

Proprietors

Russell Mark Constant and Rozlyn Ann Constant

Interests

Fencing Agreement in Transfer 269442
11159479.2 Mortgage to Bank of New Zealand - 2.7.2018 at 3:47 pm

KARAKA ROAD

20.70

Pt 13
950m²

45.87

45.87

20.70

DP 23811
DS Exd KP



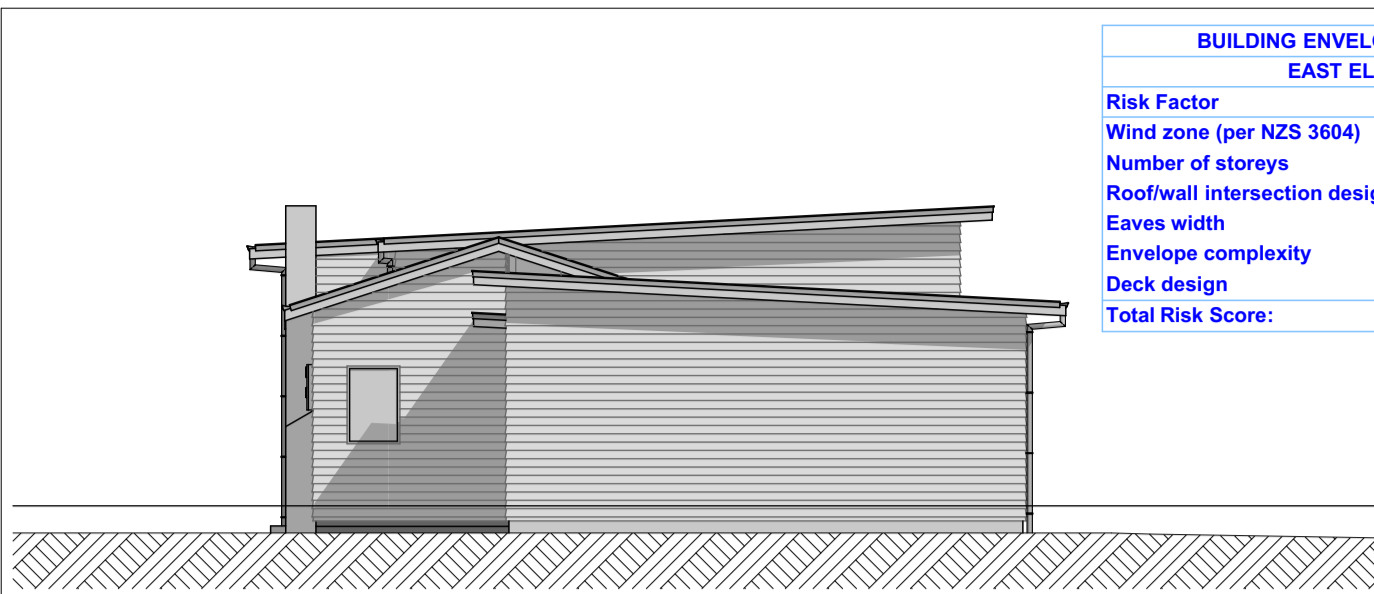

EAST ELEVATION
1:100

BUILDING ENVELOPE RISK MATRIX		
EAST ELEVATION		
Risk Factor	Risk	Severity Risk Score
Wind zone (per NZS 3604)	High risk	1
Number of storeys	Low risk	0
Roof/wall intersection design	Very high risk	5
Eaves width	High risk	2
Envelope complexity	Low risk	0
Deck design	Low	0
Total Risk Score:		8

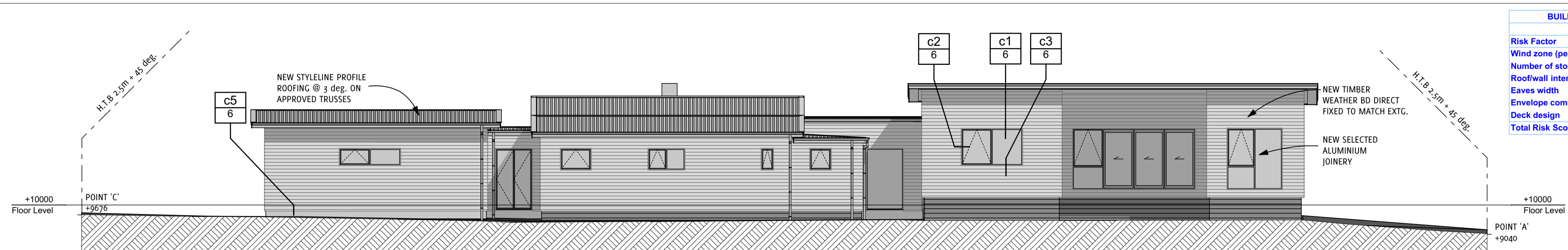

NORTH ELEVATION
1:100

BUILDING ENVELOPE RISK MATRIX		
NORTH ELEVATION		
Risk Factor	Risk	Severity Risk Score
Wind zone (per NZS 3604)	High risk	1
Number of storeys	Low risk	0
Roof/wall intersection design	High risk	3
Eaves width	High risk	2
Envelope complexity	Low risk	0
Deck design	Low	0
Total Risk Score:		6

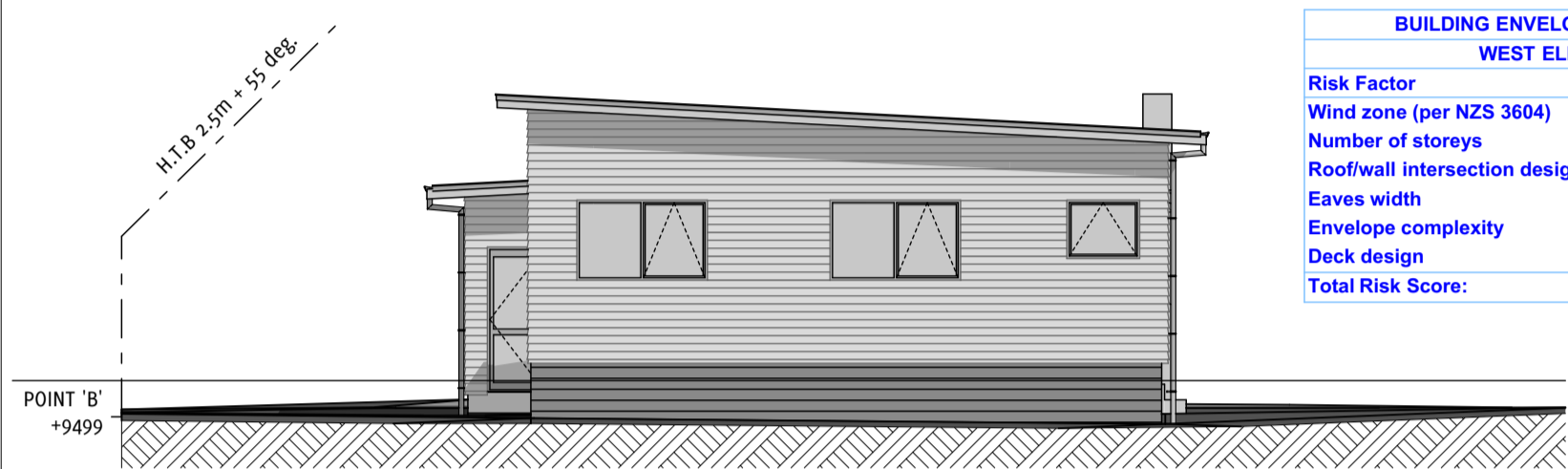

WEST ELEVATION
1:100

BUILDING ENVELOPE RISK MATRIX		
WEST ELEVATION		
Risk Factor	Risk	Severity Risk Score
Wind zone (per NZS 3604)	High risk	1
Number of storeys	Low risk	0
Roof/wall intersection design	Very high risk	5
Eaves width	High risk	2
Envelope complexity	Low risk	0
Deck design	Low	0
Total Risk Score:		8

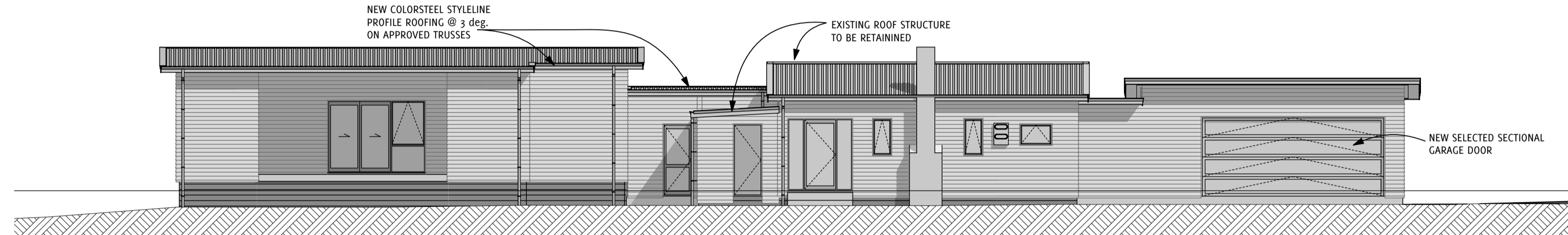

SOUTH ELEVATION
1:100

BUILDING ENVELOPE RISK MATRIX		
SOUTH ELEVATION		
Risk Factor	Risk	Severity Risk Score
Wind zone (per NZS 3604)	High risk	1
Number of storeys	Low risk	0
Roof/wall intersection design	Very high risk	5
Eaves width	High risk	2
Envelope complexity	Low risk	0
Deck design	Low	0
Total Risk Score:		8

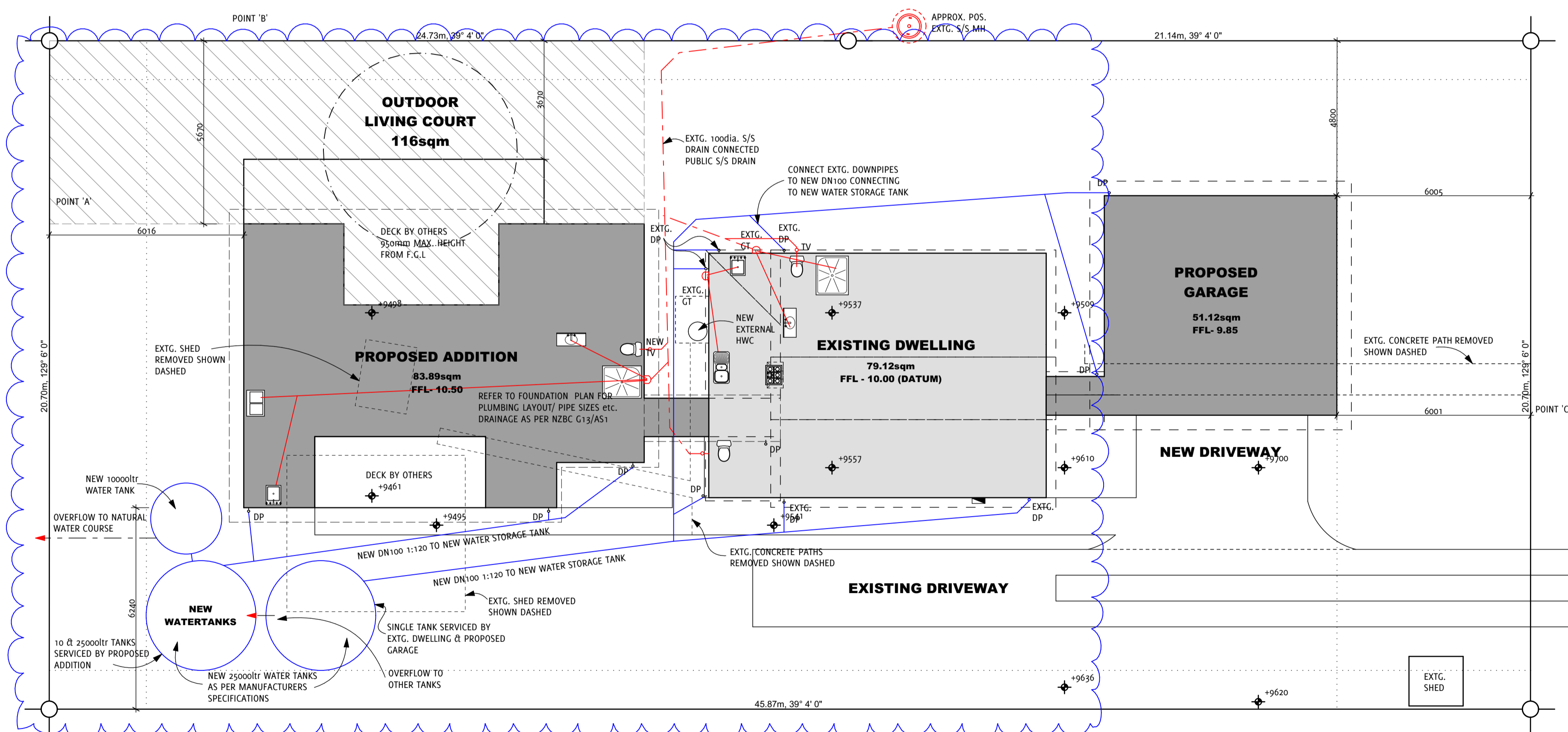

3 KARAKA ROAD

SITE PLAN
1:100

NOTES

- SHOULD THERE BE ANY DISCREPANCIES BETWEEN DRAWINGS AND SPECIFICATION FOUND, THE DESIGNER SHALL BE CONTACTED IMMEDIATELY FOR CLARIFICATION BEFORE PROCEEDING WITH THE WORKS.
- NO SUBSTITUTION TO ANY PRODUCTS OR DETAILS WITHOUT THE DESIGNERS APPROVAL IN WRITING.
- ALL LEVELS AND DIMENSIONS ARE TO BE CHECKED AND VERIFIED ON SITE BY THE CONTRACTOR PRIOR TO COMMENCEMENT OF WORKS BEFORE ANY MANUFACTURE OR CONSTRUCTION. DO NOT SCALE FROM DRAWINGS. USE FIGURED DIMENSIONS ONLY.
- ALL WORK TO COMPLY WITH NZBC & RELEVANT CODES & NZS604:2011 UNLESS SPECIFICALLY DESIGNED.

SITE DETAILS	
ADDRESS:	3 KARAKA ROAD, KAWAKAWA BAY
DURABILITY ZONE:	D
EARTHQUAKE ZONE:	1
WINDZONE:	HIGH
LEGAL DESCRIPTION:	PT LOT 13, DP 23811
SITE AREA:	950m ²
ZONING:	RESIDENTIAL SETTLEMENT UNSERVICED
SITE COVERAGE	
MAX. 35% OF	950 m ²
= 332.5m ²	
EXISTING DWELLING	79.12 m ²
PROPOSED GARAGE	51.12 m ²
PROPOSED ADDITIONS	83.89 m ²
PROPOSED VERANDAH AREAS	23.67 m ²
TOTAL AREA	237.8 m ²
THUS COMPLIES	(25.03%)
EARTHWORKS	
SCRAPE OF PROPOSED ADDITION AREA	219m ² x 0.1
	=21.9m ³

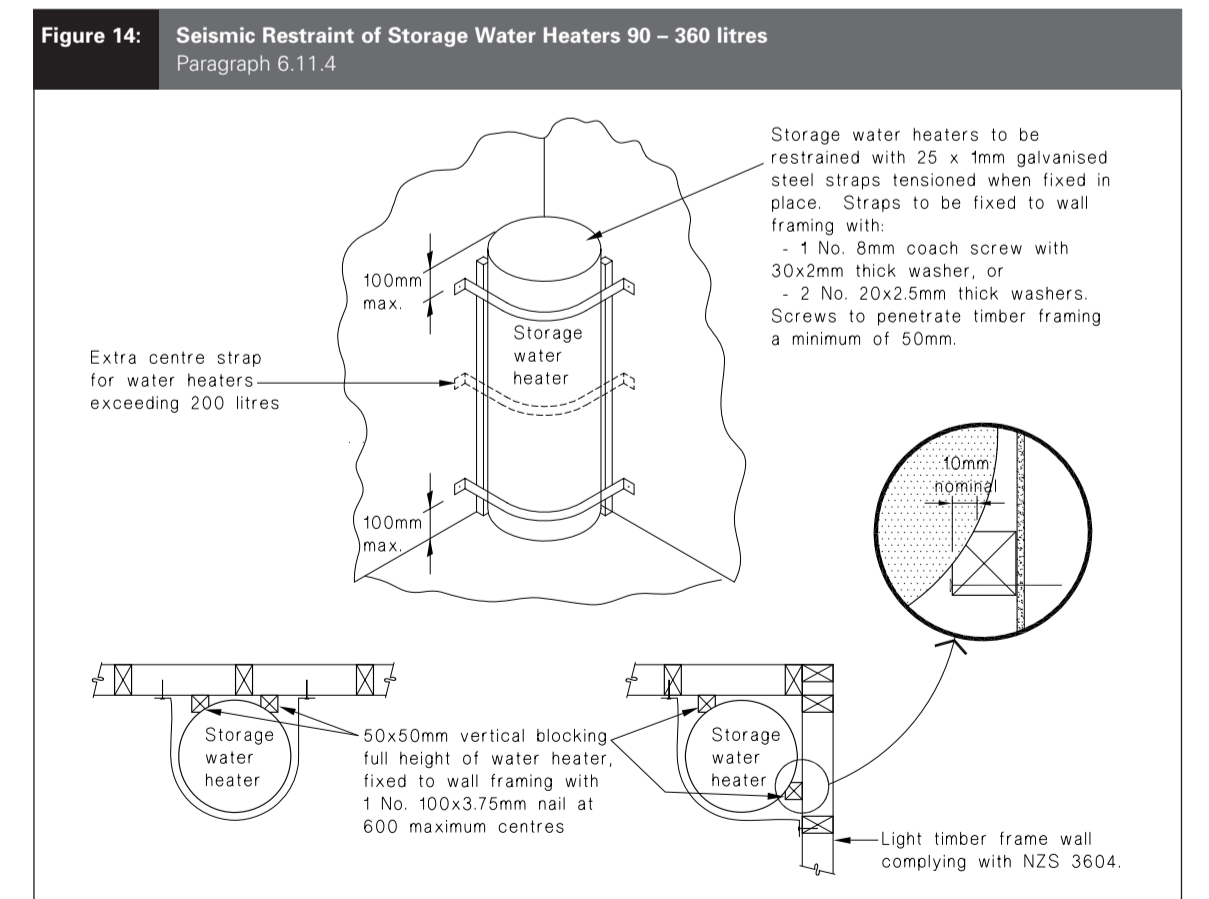

No.	Date	REVISION	By	No.	Date	ISSUE	By
B	3/4/2014	S/W, DRAINAGE		4	27/02/2013	BUILDING CONSENT	JH
A	3/4/2013	WATER TANK DETAIL, DIRECT FIX NOTE		3	12/11/2012	PRELIMINARY COSTING	PT
				2	01/11/2012	SCHEME PLAN 2	PT
				1	20/10/2012	SCHEME PLAN 1	PT



Project Name
PROPOSED ADDITIONS & ALTERATIONS TO EXISTING RESIDENCE

Project Address
3 KARAKA ROAD KAWAKAWA BAY

Client Name
Mr. G. SUMMERVILLE & Ms. A THOMSON

Drawing Status
CONSENT ISSUE

Sheet Contents
SITE PLAN, ELEVATIONS

ORIGINAL DRAWING AT A1 SIZE
A3 REDUCTION: 50%.

Dwg Date: 27/02/2013

Plot Date: 09/02/2013

Project Ref
12-200

Drawing No. 1 Rev B

OF 6

LINTEL FIXING OPTIONS

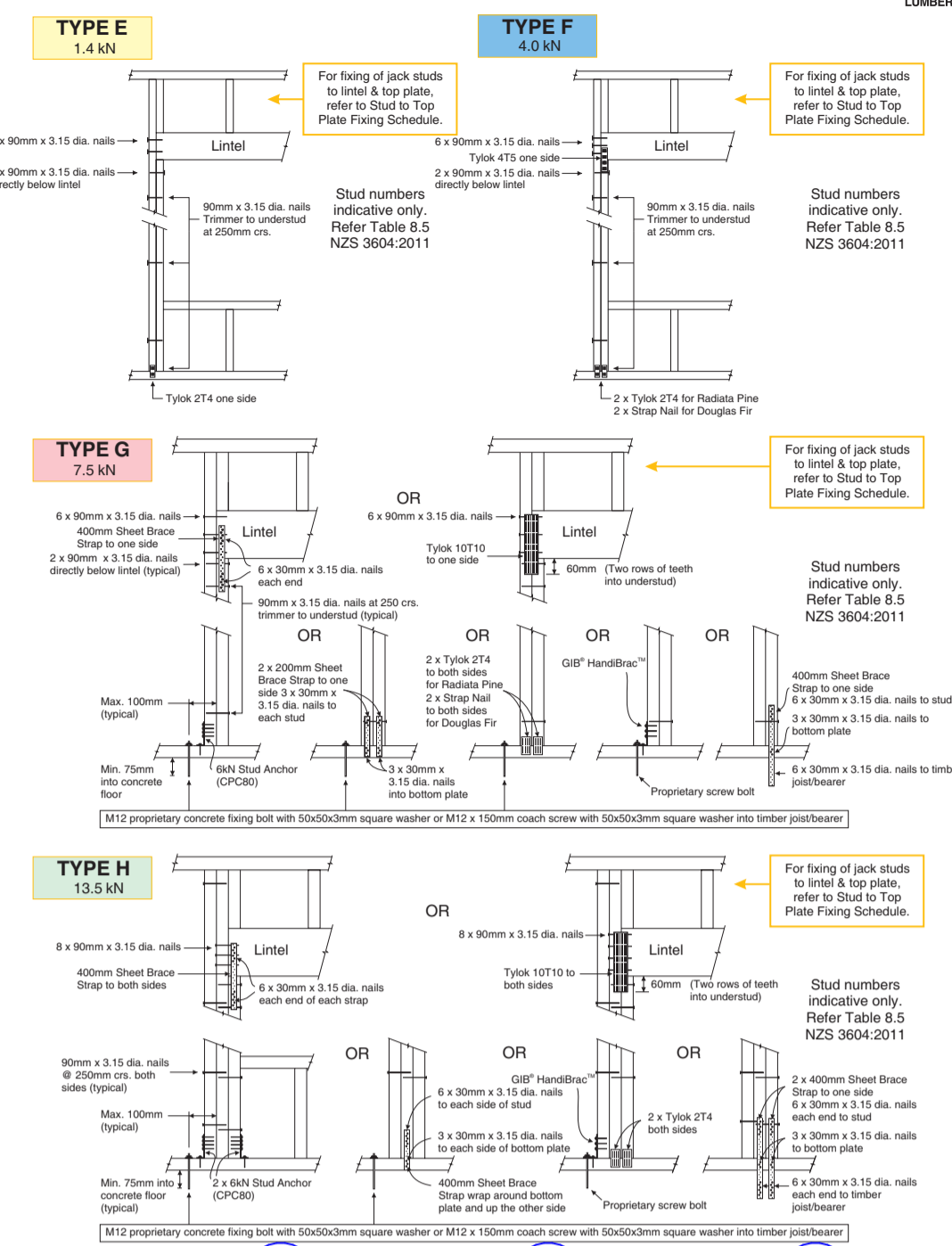

Bottom Plate Fixing

Brace type	Bottom plate fixings for GIB® Bracing Elements	
	Concrete slabs	Timber floors
GS1-N	As per NZS 3604:2011. No specific additional fastening required	As per NZS 3604:2011. Alternatively use 75 x 3.8mm shot-fired fasteners with 16mm washers, 150mm and 300mm from each end of the bracing element and at 600mm thereafter.
GS2-N	Not applicable	
GSP-H BL1-H BLP-H	Intermediate fastenings to comply with NZS 3604:2011. In addition: GIB Handibrac® fixings or metal wrap-around strap fixings and bolt as illustrated on pages 19 and 20.	Pairs of 100 x 3.75mm flat head hand driven nails or 3/190 x 3.15mm power driven nails at 600mm centres in accordance with NZS 3604:2011.
BLG-H	Not applicable	As for GSP-N, BL1-H, BLP-H on concrete slab above

Bottom Plate Fixing Solutions Table

Bottom Plate Location	Fixing Requirements			Installation	
	Bottom Plate Fixing Requirement	Concrete Strength (MPa)	Floor Edge Type	Fastener	Max Spacing / Min Edge Distance
External Wall	NZS3604:1999	17.5 MPa	Concrete	121208PA**	900 mm ² / 55 mm
	NZS3604:2011†	17.5 MPa	Masonry Block	AS12150H**† AS12150GH**†	600 mm
Internal Wall	NZS3604:1999	17.5 MPa	N/A	121208PA**	900 mm / N/A
	NZS3604:2011	17.5 MPa	N/A	Bx75 Drive Pin & Washer	600 mm / N/A

Solutions are suitable when fixing a 90x45 Bottom Plate.
 1 - To be used in conjunction with a 50x50x3 washer.
 2 - To use in conjunction with a Fryda Bracing Anchor bracket.
 3 - To meet NZS3604:2011, Masonry Block requirements. Max spacing = 600mm.

INSULATION REQUIREMENTS:

- R2.9 INSULATION TO CEILING
- R2.2 INSULATION TO WALLS
- DOUBLE GLAZED ALUMIN. JOINERY exc. GARAGE
- R1.4 EXPOL INSULATION TO SUBFLOOR

REFER TO H1 COMPLIANCE REPORT BY DESIGN NAVIGATOR IN SPECIFICATION

SMOKE ALARMS

SMOKE ALARMS TO BE TYPE 1 UNITS WITH A HUSH BUTTON & TEST BUTTON. THEY MUST COMPLY WITH AT LEAST ONE OF THE FOLLOWING STANDARDS: UL 217, CAN/ULC 5531, AS 3786 OR BS 5446: Part 1.

ALARMS TO BE LOCATED IN ESCAPE ROUTES ON ALL LEVELS. LEVELS CONTAINING SLEEPING SPACES MUST BE INSTALLED WITHIN THE SLEEPING SPACE, OR WITHIN 3 METRES OF EVERY SLEEPING SPACE DOOR. THEY MUST ALSO BE AUDIBLE THROUGH CLOSED DOORS. INSTALL ON OR NEAR CEILING IN ACCORDANCE WITH AS 1630.6 AND THE MANUFACTURERS INSTRUCTIONS.

LINTEL/ BEAM SIZES

LINTELS HAVE BEEN SIZED USING NZS 3604:2011 & HYNEBEAM SOFTWARE

WATERPROOFING

WET AREAS WATERPROOFED BEHIND TILES WITH WET SEAL FIBRE COAT WATERPROOFING MEMBRANE. MEMBRANE TO BE APPLIED IN STRICT ACCORDANCE WITH MANUFACTURERS SPECIFICATIONS.

STUD SIZES & SPACING

SINGLE OR TOP STOREY (high wind)

FOR EXTERNAL LOAD BEARING WALLS	
MAX STUD LENGTH (mm)	STUD SIZE AND SPACING
2400	90x45 SC8 @ 600CRS
3000	90x45 SC8 @ 300CRS

FOR EXTERNAL NON LOAD BEARING WALLS	
MAX STUD LENGTH (mm)	STUD SIZE AND SPACING
2400	90x45 SC8 @ 600CRS

FOR INTERNAL LOAD BEARING WALLS	
MAX STUD LENGTH (mm)	STUD SIZE AND SPACING
2400	70x45 SC8 @ 600CRS

FOR INTERNAL NON LOAD BEARING WALLS	
MAX STUD LENGTH (mm)	STUD SIZE AND SPACING
2400	70x45 SC8 @ 600CRS

NOTES:

OPENINGS ARE ALLOWED WITHIN THE MIDDLE THIRD OF A WALL BRACING ELEMENT'S LENGTH AND HEIGHT. NEITHER OPENING DIMENSION SHALL BE MORE THAN ONE THIRD OF THE ELEMENT HEIGHT. WALL LININGS ARE FIXED TO OPENING TRIMMERS AT 150mm CENTRES. SMALL OPENINGS (E.G., POWER OUTLETS) OF 90 x 90mm OR LESS MAY BE PLACED NO CLOSER THAN 90mm TO THE EDGE OF THE BRACED ELEMENT. A BLOCK MAY NEED TO BE PROVIDED ALONGSIDE THE PERIMETER STUD.

DOWNLIGHTS TO BE 'CA', 'RA', OR 'OA' TYPE FITTINGS AS PER NZCEP 54

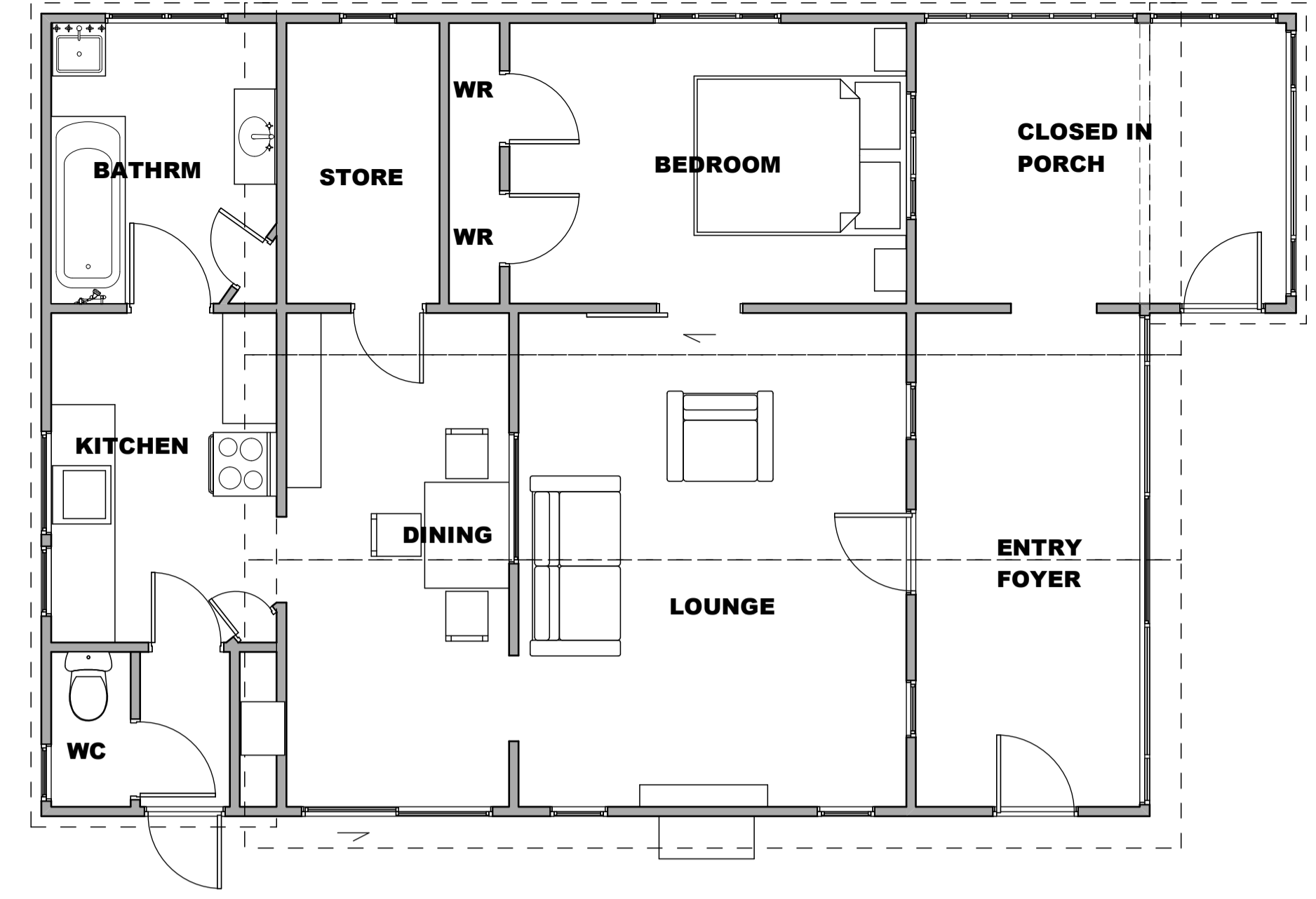

EXISTING FLOORPLAN 1:100

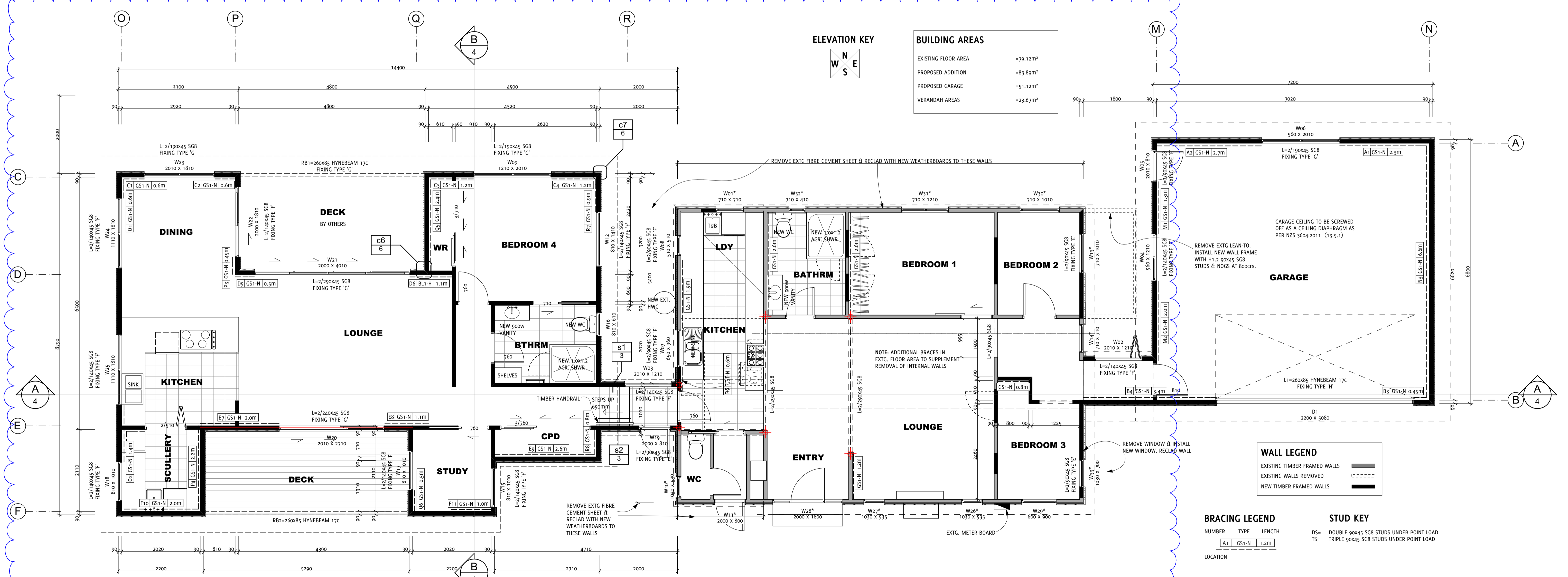

BUILDING AREAS

EXISTING FLOOR AREA	=79.12m ²
PROPOSED ADDITION	=83.89m ²
PROPOSED GARAGE	=51.12m ²
VERANDAH AREAS	=23.67m ²

WALL LEGEND

EXISTING TIMBER FRAMED WALLS	
EXISTING WALLS REMOVED	
NEW TIMBER FRAMED WALLS	

BRACING LEGEND

NUMBER	TYPE	LENGTH
A1	GS1-N	1.2m

LOCATION

STUD KEY

DS-	DOUBLE 90x45 SC8 STUDS UNDER POINT LOAD
TS-	TRIPLE 90x45 SC8 STUDS UNDER POINT LOAD

FLOOR PLAN 1:50

No.	Date	REVISION	By	No.	Date	ISSUE	By
B	3/4/2014	FLOOR PLAN CONFIG., WINDOWS, BRACES		4	27/02/2013	BUILDING CONSENT	JH
A	3/4/2013	BRACE LINE 'R'		3	12/11/2012	PRELIMINARY COSTING	PT
				2	01/11/2012	SCHEME PLAN 2	PT
				1	20/10/2012	SCHEME PLAN 1	PT



Copyright of this design remains the property of Blank Space Architectural Limited

Project Name
PROPOSED ADDITIONS & ALTERATIONS TO EXISTING RESIDENCE

Project Address
3 KARAKA ROAD KAWAKAWA BAY

Client Name
Mr. G. SUMMERVILLE & Ms. A THOMSON

Drawing Status	Sheet Contents	Project Ref	12-200
ORIGINAL DRAWING AT A1 SIZE			
Drawn By JH	Dwg Date: 27/02/2013	Drawing No.	2
Checked By PT	Plot Date: 09/02/2013	Rev	B
		OF	6

BLANK SPACE ARCHITECTURAL LIMITED

T: 09 238 1453 M: 0274 2000 37

E: info@blankspace.co.nz

FOUNDATION NOTES
 GARAGE - 20 SERIES CONCRETE BLOCK FOUNDATION WALL ON CONCRETE FOOTING WITH 100mm REINFORCED CONCRETE SLAB ON DPM ON 150mm LAYERS COMPACTED HARDFILL
 ADDITION - 140x45 H1.2 SG8 TIMBER JOISTS, 2/140x45 H1.2 SG8 BEARERS, 125sq H5 SENTON PILES IN CONCRETE FOOTING
 LATERAL SUPPORT & MIDSPAN NOGGING OF FLOOR JOISTS IN ACCORDANCE WITH NZS3604:2011 7.1.2
 20mm H3 CD GRADE PLYWOOD FLOORING TO WET AREAS (AS/NZS 2269) IN ACCORDANCE WITH NZS3604:2011 7.2.3.5 SCREWED & GLUE FIXED.
 20mm PARTICLE BOARD FLOORING SCREWED & GLUE FIXED.
 JOISTS IN JOISTS TO BE IN ACCORDANCE WITH FIG. 7.1 NZS3604:2011.
 DRAINLAYER TO CONFIRM PLUMBING/ DRAINAGE ROUTES BEFORE POURING OF CONCRETE SLAB. PLUMBING/ DRAINAGE AS PER AS/NZS 3500.2:2005, & NZBC G13/AS1
 CONTRACTOR TO ENSURE ALL CONCRETE ENCASED SERVICES ARE IN PLACE BEFORE POURING OF CONCRETE SLAB, WHERE SERVICE PIPES PASS THROUGH SLAB WRAP IN PROTECTIVE TAPE TO ALLOW FOR MOVEMENT. TAPE PIPES TO SEAL PENETRATIONS WHERE THEY PASS THROUGH THE DPM.

SUBFLOOR VENTILATION
 SUBFLOOR VENTILATION TO BE PROVIDED AS PER NZS3604:2011 6.1.4. CONTINUOUS 20mm WIDE SLOTS BETWEEN BASEBOARDS.

PILE LEGEND
 ALL PILES ARE TO BE 125sq H5
 OP ORDINARY PILE = 400sq (400) x 275 THICK, SET MIN. 450 BELOW C.G.L.
 BP BRACED PILE = 350sq (400) x 450 THICK, SET MIN. 450 BELOW C.G.L.
 AP ANCHOR PILE = 350sq (400) x 900 THICK, SET MIN. 900 BELOW C.G.L.
 SUBSTITUTE ANCHOR PILES WITH BRACED PILE SYSTEM (IN BOTH DIRECTIONS) IF PILE HEIGHT EXCEEDS 600mm.
 - - - INDICATES SUBFLOOR BRACE (BRACE SIZE AS PER BELOW) (ARROW POINTS TO LOWER END)
 NOT EXCEEDING 3.0m - 100x75
 NOT EXCEEDING 4.5m - 2/100x50
 NOT EXCEEDING 5.0m - 100x100

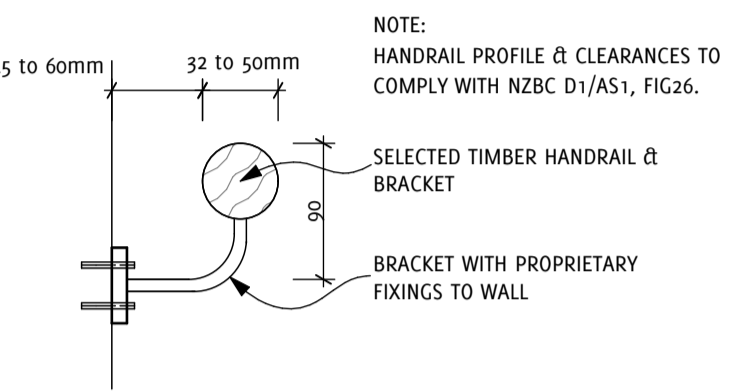

STAIR HANDRAIL DETAIL
 s1
 2 1:5

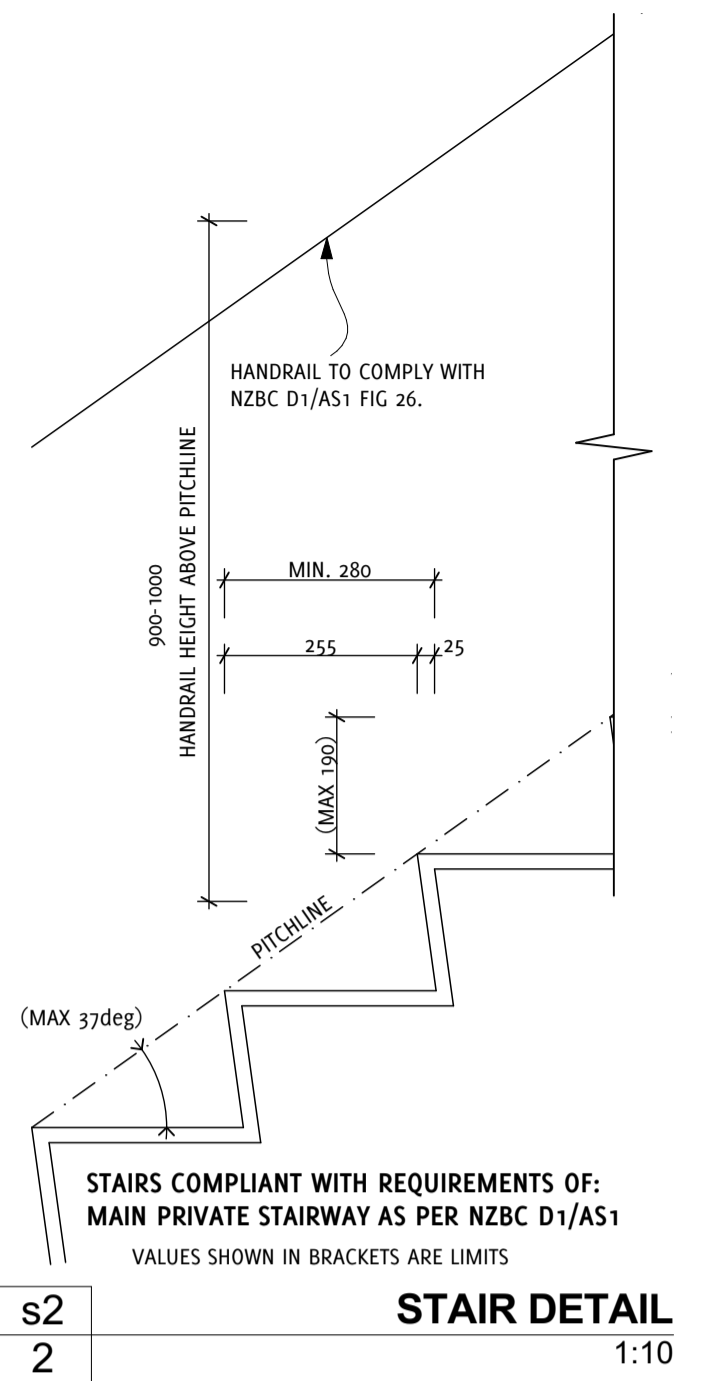

STAIR DETAIL
 s2
 2 1:10

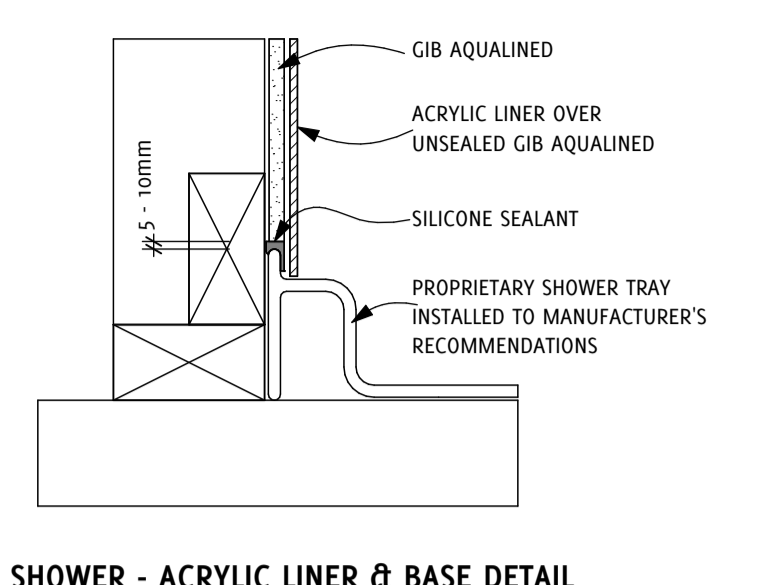

SHOWER - ACRYLIC LINER & BASE DETAIL

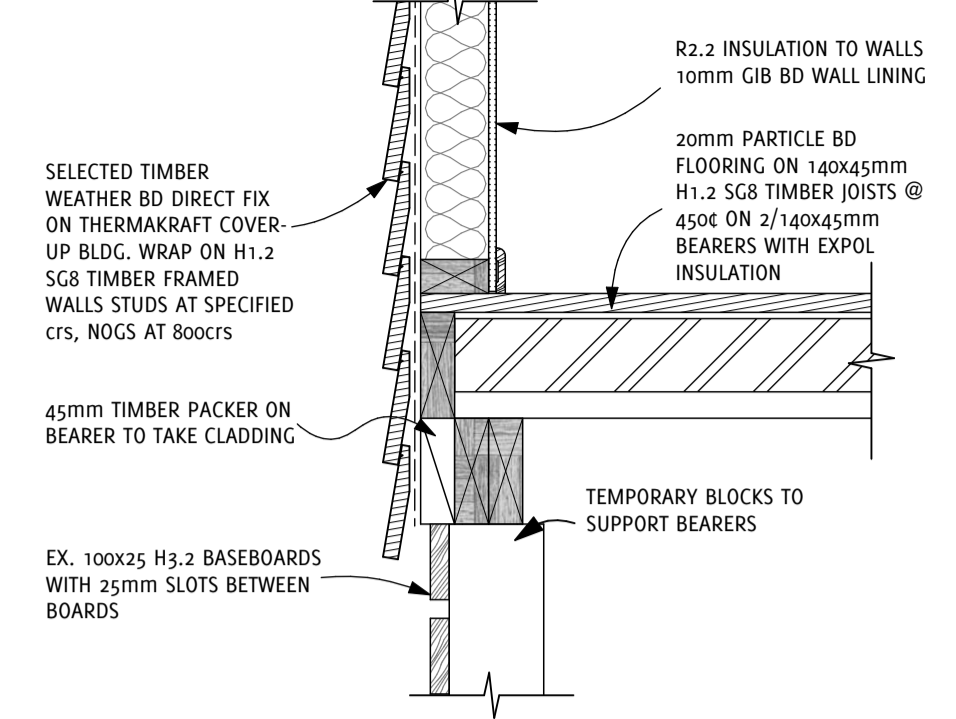

SUBFLOOR DETAIL
 f3
 3 1:10

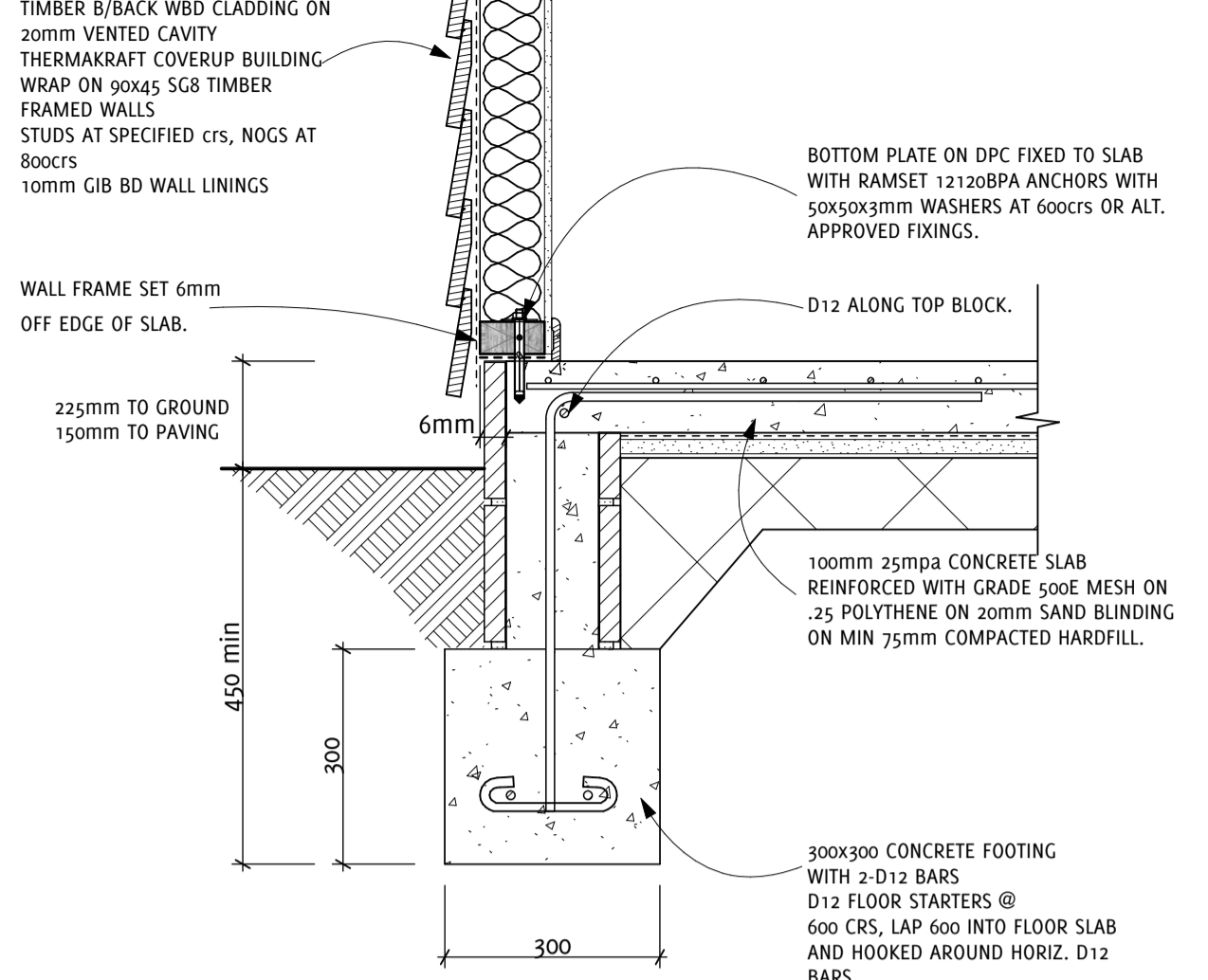

BLOCK FOUNDATION DETAIL
 f1
 3 1:10

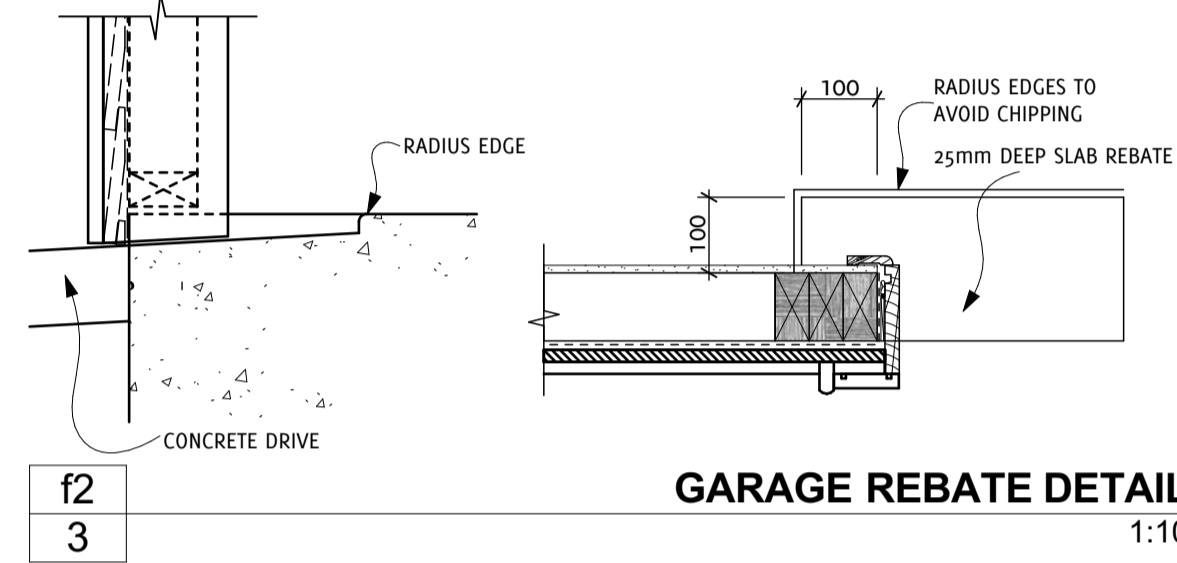

GARAGE REBATE DETAIL
 f2
 3 1:10

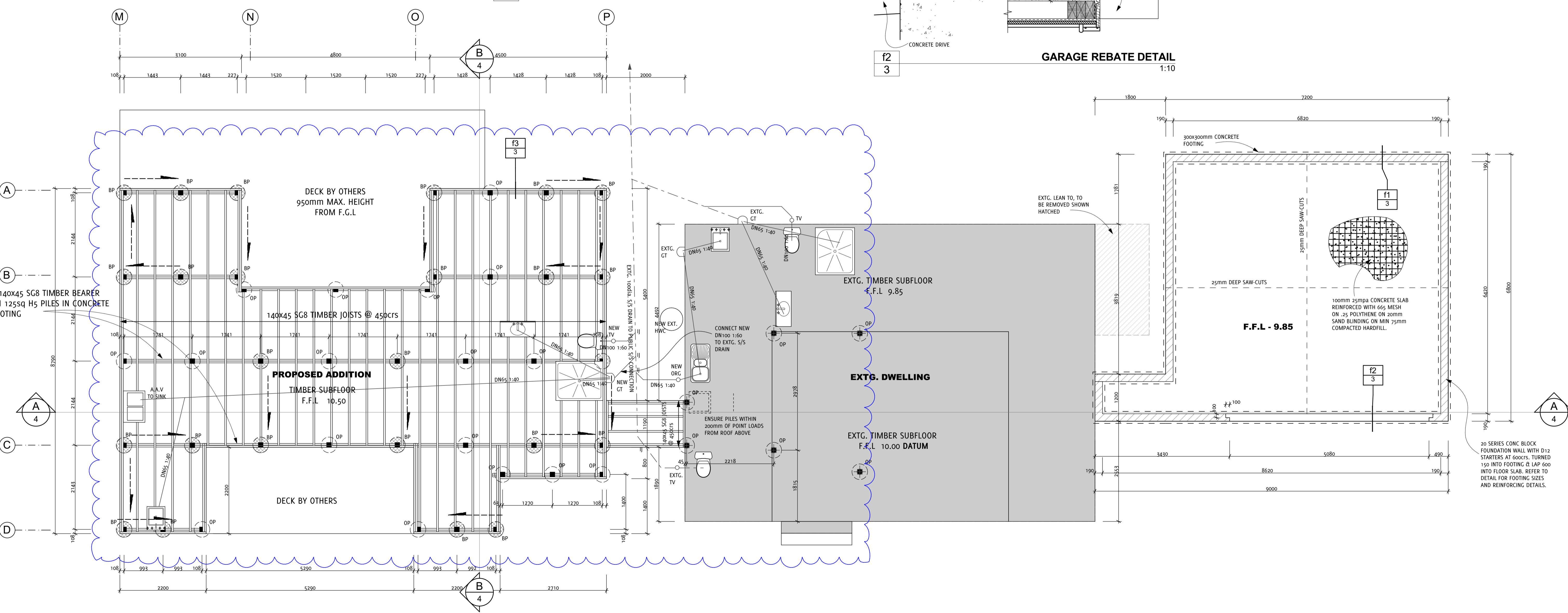

FOUNDATION PLAN
 1:50

No.	Date	REVISION	By	No.	Date	ISSUE	By
				4	27/02/2013	BUILDING CONSENT	JH
				3	12/11/2012	PRELIMINARY COSTING	PT
				2	01/11/2012	SCHEME PLAN 2	PT
				1	20/10/2012	SCHEME PLAN 1	PT



Copyright of this design remains the property of Blank Space Architectural Limited

Project Name
PROPOSED ADDITIONS & ALTERATIONS TO EXISTING RESIDENCE
 Project Address
3 KARAKA ROAD KAWAKAWA BAY
 Client Name
Mr. G. SUMMERVILLE & Ms. A THOMSON

Drawing Status
 Sheet Contents
CONSENT ISSUE FOUNDATION PLAN
 ORIGINAL DRAWING AT A1 SIZE
 A3 REDUCTION: 50%
 Drawn By | JH
 Checked By | PT
 Dwg Date: | 27/02/2013
 Plot Date: | 09/02/2013

Project Ref
12-200
 Drawing No. | 3
 Rev | B
 OF 6

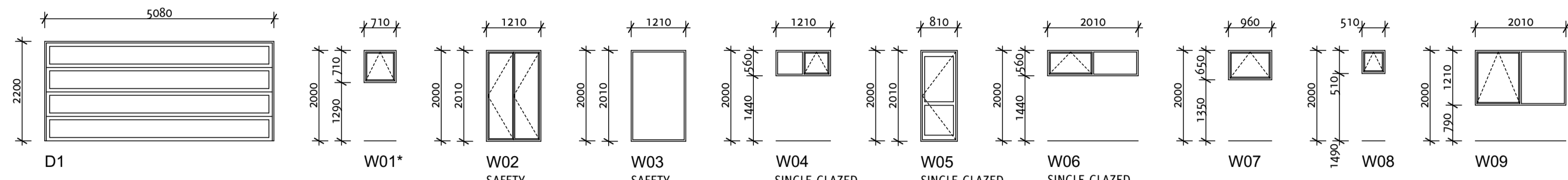

DOOR/ WINDOW NOTES:
 ALL SIZES GIVEN ARE DOOR & WINDOW TRIM OPENING SIZES.
 WINDOWS MARKED WITH ASTERISK INDICATE NEW WINDOWS IN EXISTING OPENINGS. ENSURE TO CONFIRM TRIM OPENING SIZES ON SITE PRIOR TO MANUFACTURING.
 ALL UNITS DOUBLE GLAZED UNLESS SPECIFIED OTHERWISE.
 JOINERY MANUFACTURER TO CONFIRM DOOR & WINDOW SIZES PRIOR TO MANUFACTURING.
 ALL UNITS ARE VIEWED FROM THE OUTSIDE.
 ALL GLAZING TO COMPLY WITH NZS 4223:PART 3:1999.

WINDOW/DOOR SCHEDULE
1:100

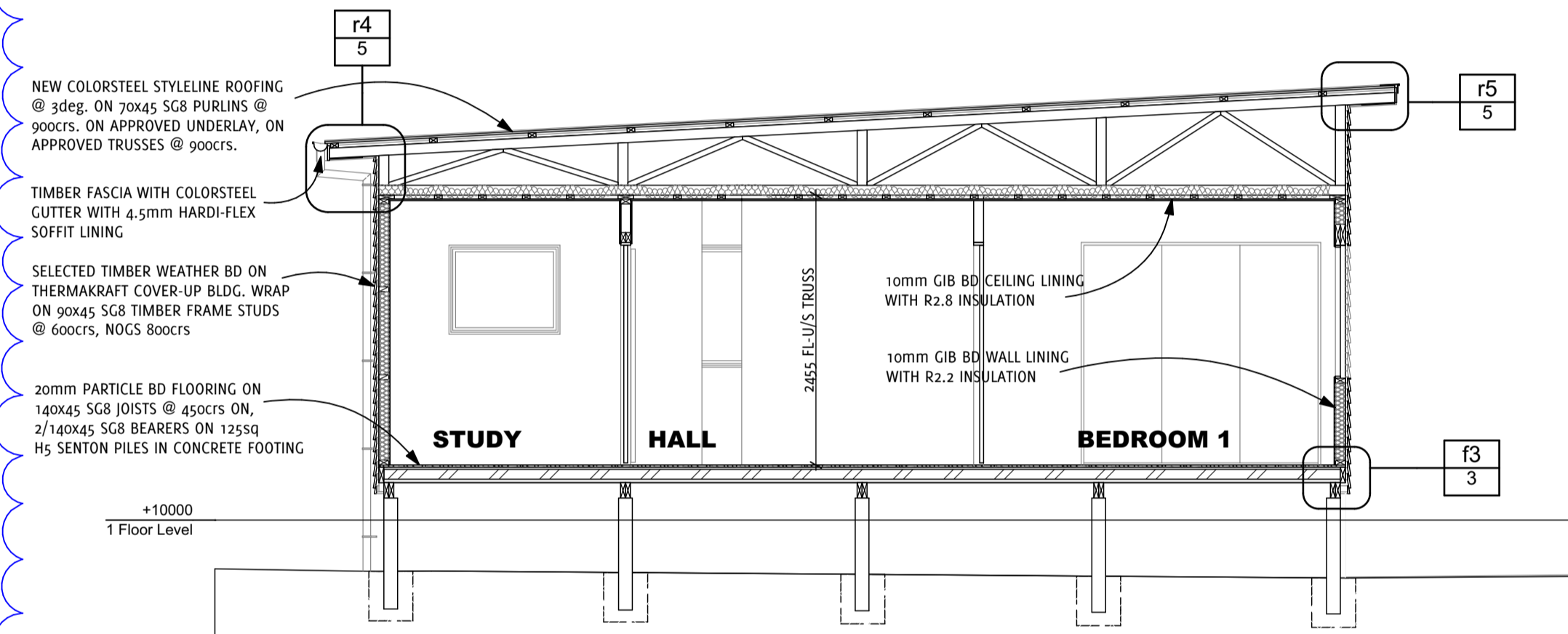

SECTION BB
1:50

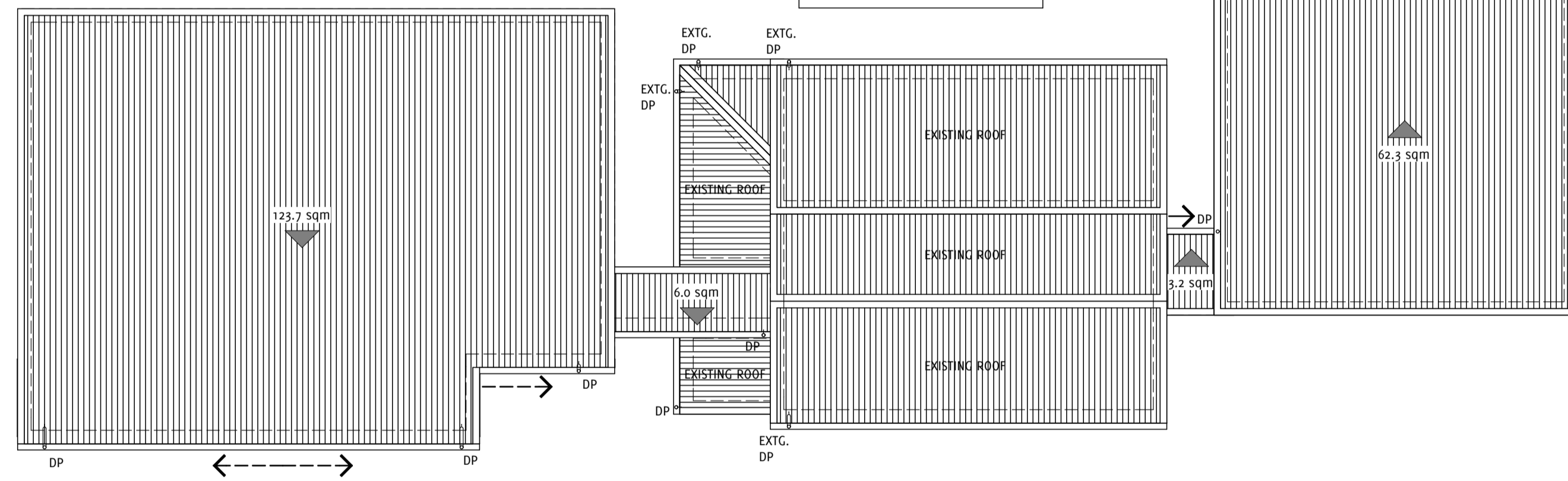

ROOF AND GUTTER PLAN
1:100

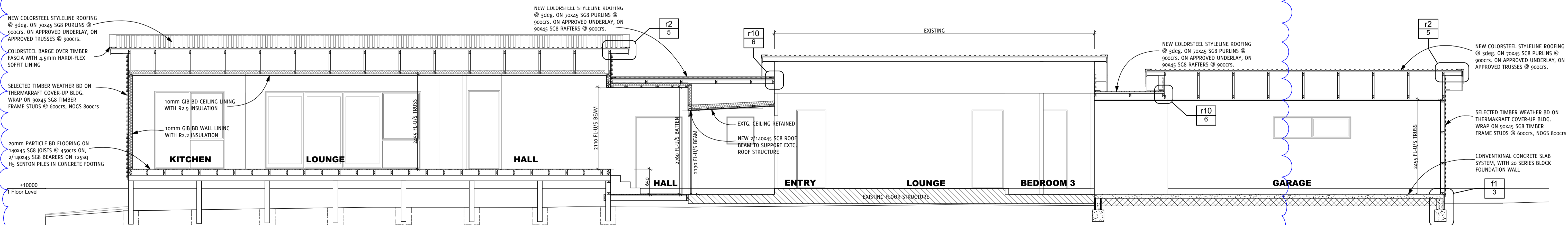

SECTION AA
1:50

ZONES	FIXING FASTENING	ENVIRONMENT	MATERIAL
ALL ZONES	Nail plates	CLOSED AND ROOF SPACES	Continuously coated galvanized steel ⁽²⁾
	Wire dogs & bolts		Hot-dipped galvanized steel ⁽²⁾
	All other structural fixings	CLOSED	Mild steel (uncoated, non-galvanized) ⁽³⁾
ZONE D	All structural fixings	SHELTERED ⁽⁴⁾ AND EXPOSED	Type 304 stainless steel ⁽⁵⁾

(1) Items described in this table are steel fasteners required to last not less than 50 years, used for joining timber, such as nail plates, bolts, brackets, wire dogs and similar, but not including nails or screws (which are described in table 4.3).
 (2) All galvanizing weights to steel shall be as given in table 4.2.
 (3) Steel fixings in timber treated with copper-based timber preservatives shall be as per 4.4.4.
 (4) "Sheltered" shall be that above a 45° line drawn from the lower edge of a projecting weathertight structure such as a floor, roof or deck. "Exposed" shall be below that 45° line. See figure 4.3(a) and (b).
 (5) Type 304 stainless steel is sufficient to comply with NZBC requirements, but may have surface rust. Type 316 may be used where appearance is a consideration but exceeds the requirements of the NZBC.
 (6) "Fabricated brackets" shall be made from 5 mm (minimum thickness) mild steel and shall be hot-dipped galvanized.

NZS3604-2011 DURABILITY CHART

FOR FULL DETAILS CHECK B2/AS1

WHERE TIMBER TREATMENTS ARE USED

Level	Species	Building Element
Floor framing protected from weather but exposed to ground atmosphere		
H1.2	Radiata pine Douglas fir	Jackstuds, subfloor braces, wall plates, floor joists to the subfloor, blocking, walings and battens, noggs and diagonal boards
H1.2	Radiata pine Douglas fir	Interior solid wood flooring for ground floors
Enclosed roof framing and trusses		
H1.2	Radiata pine Douglas fir	Sarking and framing not protected from solar-driven moisture through absorbent cladding materials
H1.2	Radiata pine Douglas fir	Enclosed flat roof framing and associated roof members
H1.2	Radiata pine Douglas fir	Enclosed skillion roof framing and associated roof members
H1.2	Radiata pine Douglas fir	Valley boards and boards supporting flashings for box gutters, roof penetrations and upstands to roof decks
H1.2	Radiata pine Douglas fir	All roof trusses, including gable end trusses, roof framing, ceiling and eaves framing, purlins and battens
Enclosed wall framing protected from the weather		
H1.2	Radiata pine Douglas fir	Framing and other members within or beneath a parapet
H1.2	Radiata pine Douglas fir	Framing and other members within enclosed decks or balconies (see H3.2 for cantilevered decks)
H3.2	Radiata pine	Framing and other members within enclosed cantilevered decks (including joist trimmers, noggs and blocking)
Enclosed wall framing protected from the weather continued		
H1.2	Radiata pine Douglas fir	Framing and other members supporting enclosed decks or balconies (including for cantilevered decks)
H3.1	Radiata pine	Battens used behind cladding to form a cavity (H3.1 treatments can be either solvent-based or boron. H3.1 boron treatments supplied grey primer-painted)
H1.2	Radiata pine Douglas fir	All other exterior wall framing and other members including exterior and boundary joists
Internal wall framing		
H1.2	Radiata pine Douglas fir	Internal walls
Mid-floor framing		
H1.2	Radiata pine Douglas fir	All mid-floor framing, including boundary joists, ceiling framing and ceiling battens and double top plates
Interior flooring		
H1.2	Pinus species Douglas fir	Interior flooring
Other framing		
None	Radiata pine Douglas fir	Wall framing and roof framing (including trusses) protected from the weather, in unlined and unoccupied farm buildings and outbuildings, except buildings with high internal humidity, such as saunas, spas etc
H3.2	Radiata pine	Framing exposed to the weather and above ground
H4	Radiata pine	Framing, such as fence posts and landscape timbers, that is exposed to the weather and is in contact with the ground
H5	Radiata pine	Framing, such as house piles, poles and crib walling, that is exposed to the weather and is in contact with the ground

Note 1: For structural use of other species, refer to NZS 3602:2003 Tables 1 and 2.
Note 2: For non-structural use of radiata pine, Douglas fir and other species, refer to NZS 3602:2003 Table 3.
Note 3: A higher treatment level also satisfies the level specified in this table.

TIMBER TREATMENT TABLE

No.	Date	REVISION	By	No.	Date	ISSUE	By
4	27/02/2013	BUILDING CONSENT	JH				
3	12/11/2012	PRELIMINARY COSTING	PT				
2	01/11/2012	SCHEME PLAN 2	PT				
1	20/10/2012	SCHEME PLAN 1	PT				



Project Name: **PROPOSED ADDITIONS & ALTERATIONS TO EXISTING RESIDENCE**
 Project Address: **3 KARAKA ROAD KAWAKAWA BAY**
 Client Name: **Mr. G. SUMMERVILLE & Ms. A THOMSON**

Drawing Status: **CONSENT ISSUE**
 Sheet Contents: **SECTIONS, ROOF & GUTTER PLAN, WINDOW SCHEDULE**
 ORIGINAL DRAWING AT A1 SIZE
 A3 REDUCTION: 50%
 Drawn By: JH
 Checked By: PT
 Dwg Date: 27/02/2013
 Plot Date: 09/02/2013

Project Ref: **12-200**
 Drawing No.: **4**
 Rev: **B**
 OF **6**

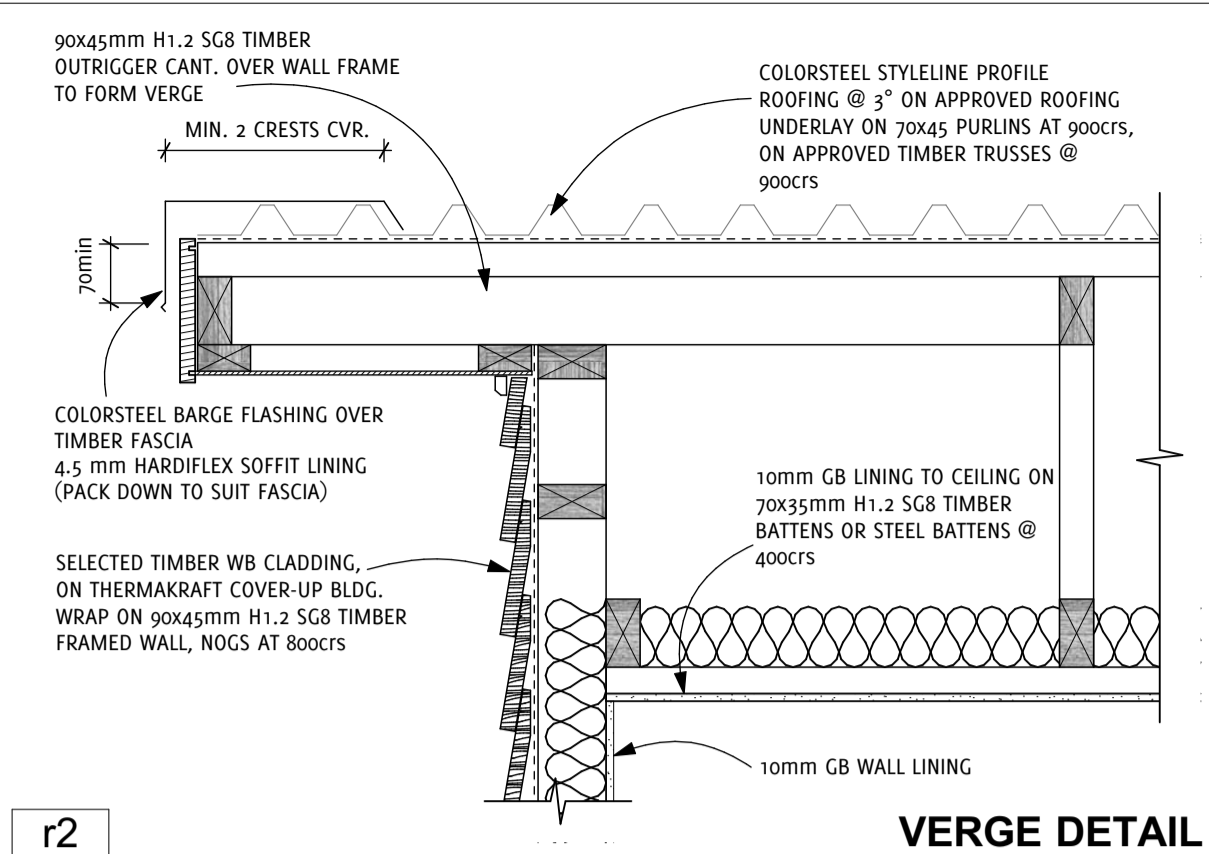

r2
5

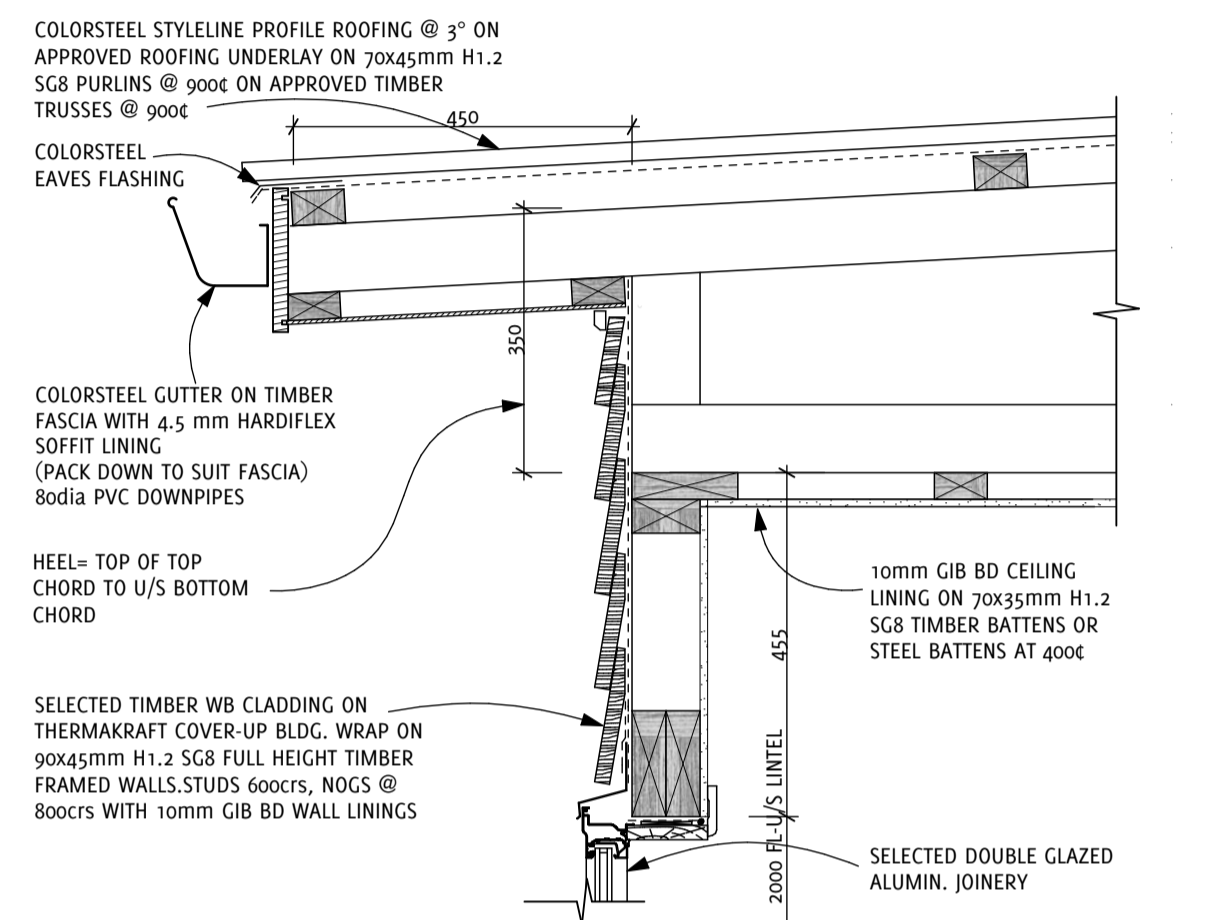

r1
5

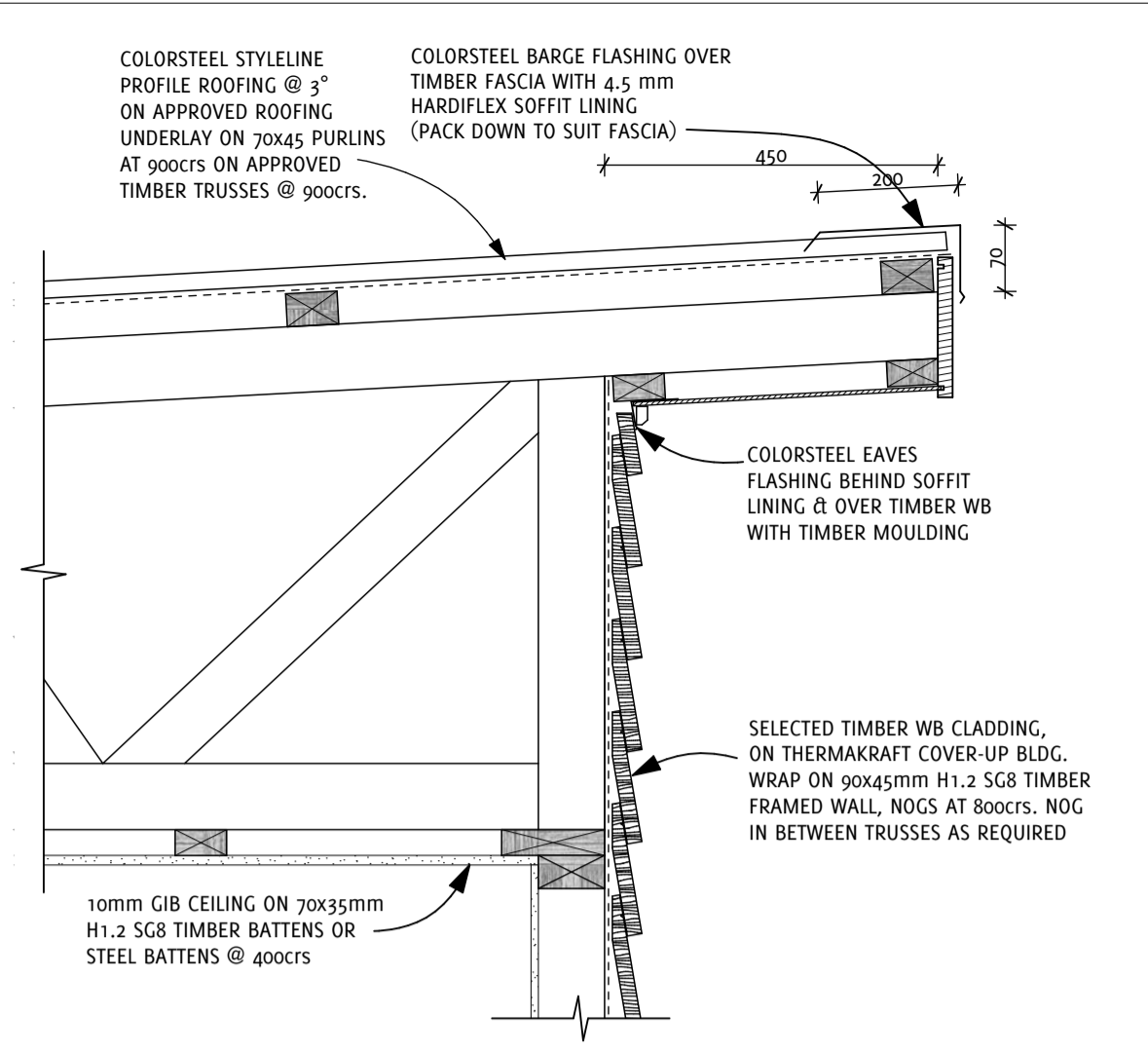

r3
5

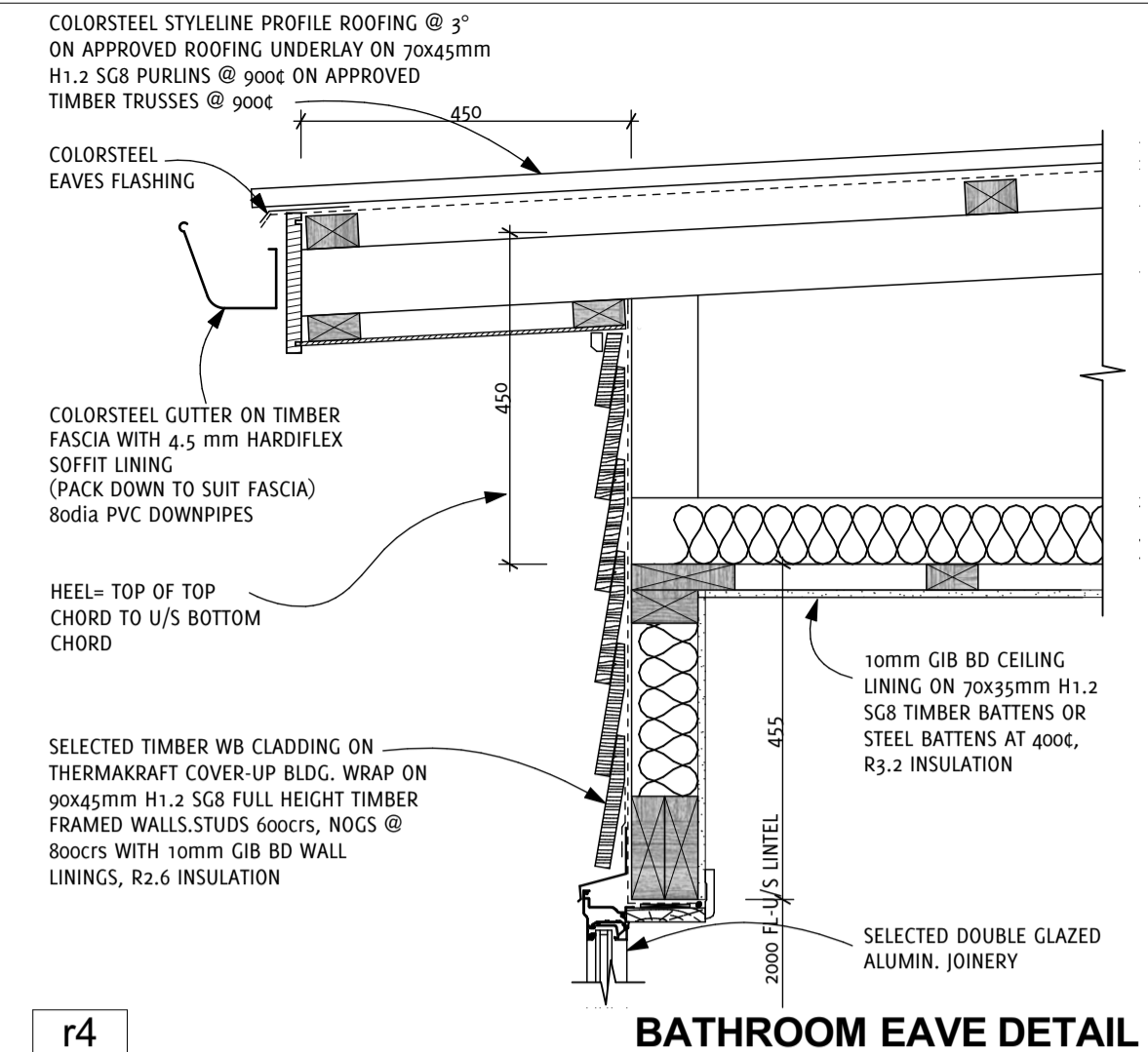

r4
5

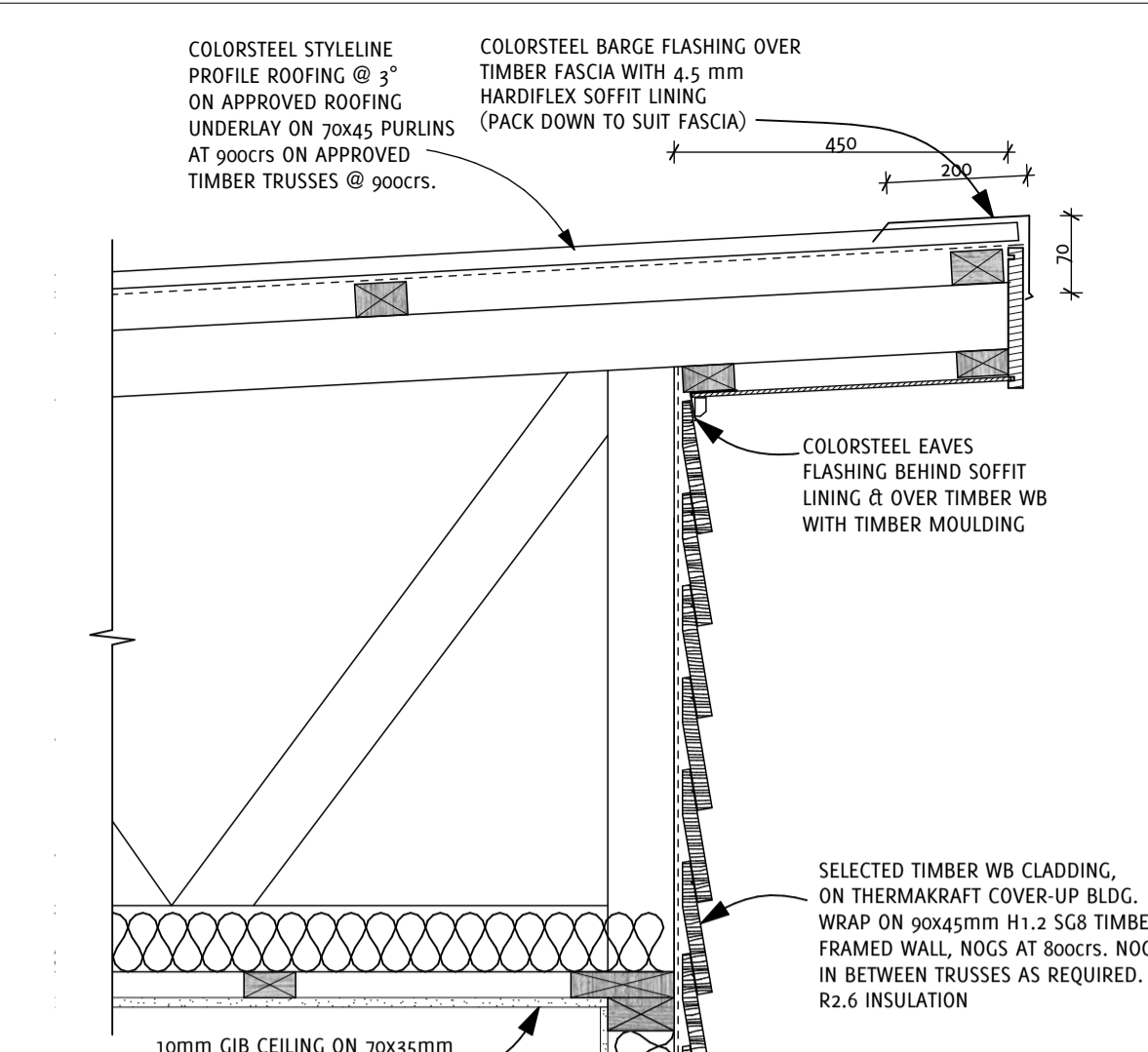

r5
5

ALTERNATE STUD TO TOP PLATE FIXING OPTIONS AS PER MITEK 2012

FIXING TYPE A 0.7 kN
2 x 90mm x 3.15 dia. plain steel wire nails driven vertically into stud.

FIXING TYPE B 4.7 kN CHOOSE ANY OF THE 3 OPTIONS BELOW
2 x 90mm x 3.15 dia. plain steel wire nails driven vertically into stud.
Plus LUMBERLOK 6KN Stud Anchor (CPC80)
Plus 2 x LUMBERLOK CPC40
Recommended for internal wall options to avoid lining issues.

2 x 90mm x 3.15 dia. plain steel wire nails driven vertically into stud.
Plus LUMBERLOK Stud Strap (one face only)

Note:
To calculate the number of B type fixings required, divide the wall length by the stud centres, add 1 to this figure and locate this number of fixings as evenly as possible along the wall length. This figure includes the start and end studs in each wall length.

ROOF NOTES
3deg ROOF PITCH, REFER PLAN
COLORSTEEL MAXX STYLELINE PROFILE ROOFING
TIMBER TRUSSES DESIGNED BY MANUFACTURER
TIMBER FASCIA, GUTTER TO MATCH EXISTING
OVERHANG VARIES, 4.5mm HARDIFLEX SOFFIT LINING WITH JOINTERS
80φ PAINTED PVC DOWNPIPES
WIND ZONE- HIGH
ROOF BRACING AS PER NZS3604:2011 10.3.2
1 BRACE PER 50m2 ROOF AREA, 2 PER RIDGE LINE
INDICATES POINT LOADS

ROOF FIXINGS- FOR HIGH WIND ZONE

ROOF MEMBER	FIXING DESCRIPTION	FIXING CAPACITY
TRUSSES	1 PAIR CT 200 TRUSS TIES	11.65 kN
RAFTERS	2/90x3.15 SKEW NAILS @ 2 WIRE DOGS	4.7 kN
PURLINS	1/10g SELF-DRILLING SCREW, 80mm LONG	2.4 kN
STUD TO TOP PLATE	2/90x3.15 END NAILS + 2 WIRE DOGS	4.7 kN

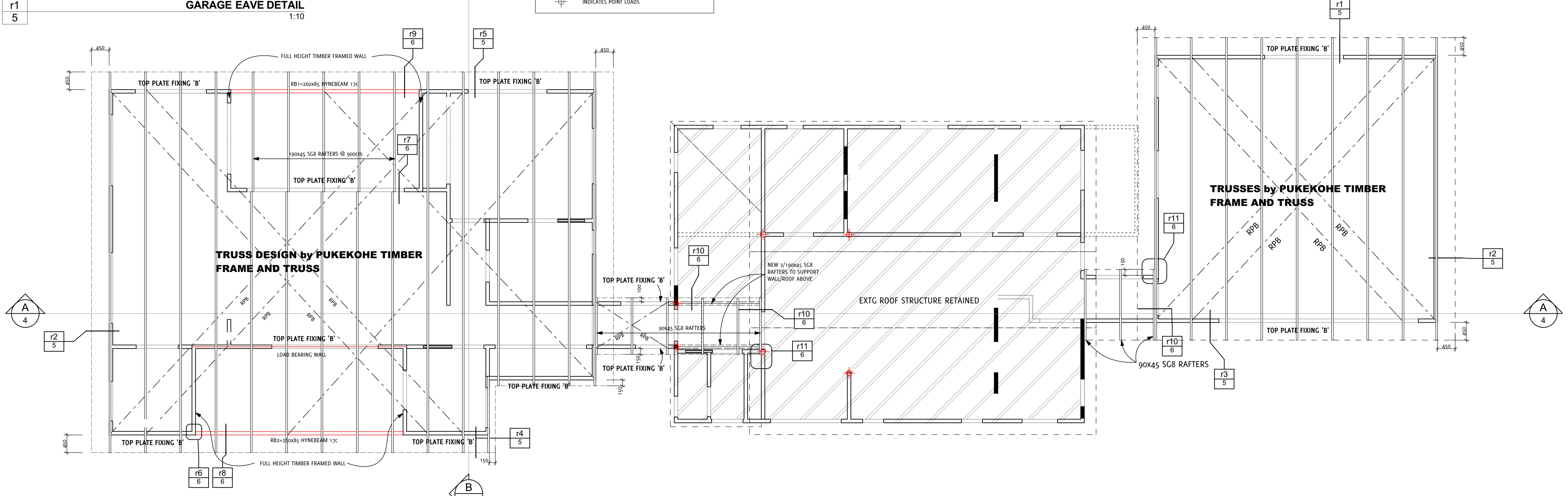

ROOF FRAMING PLAN
1:50

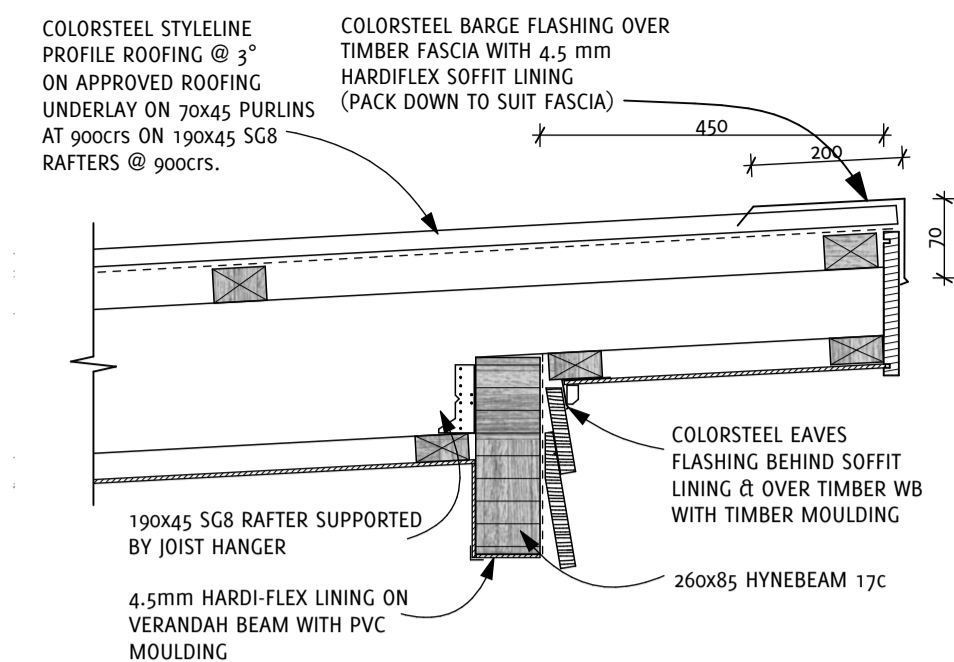

r9
5
NORTH VERANDAH BEAM DETAIL
1:10

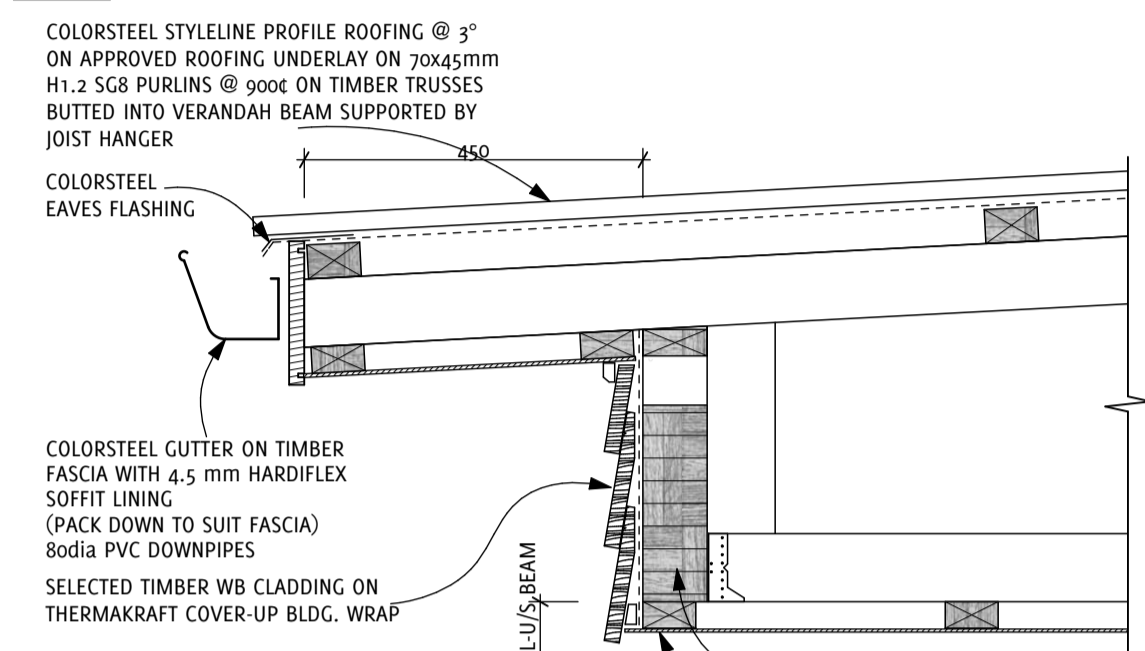

r8
5
SOUTH VERANDAH BEAM DETAIL
1:10

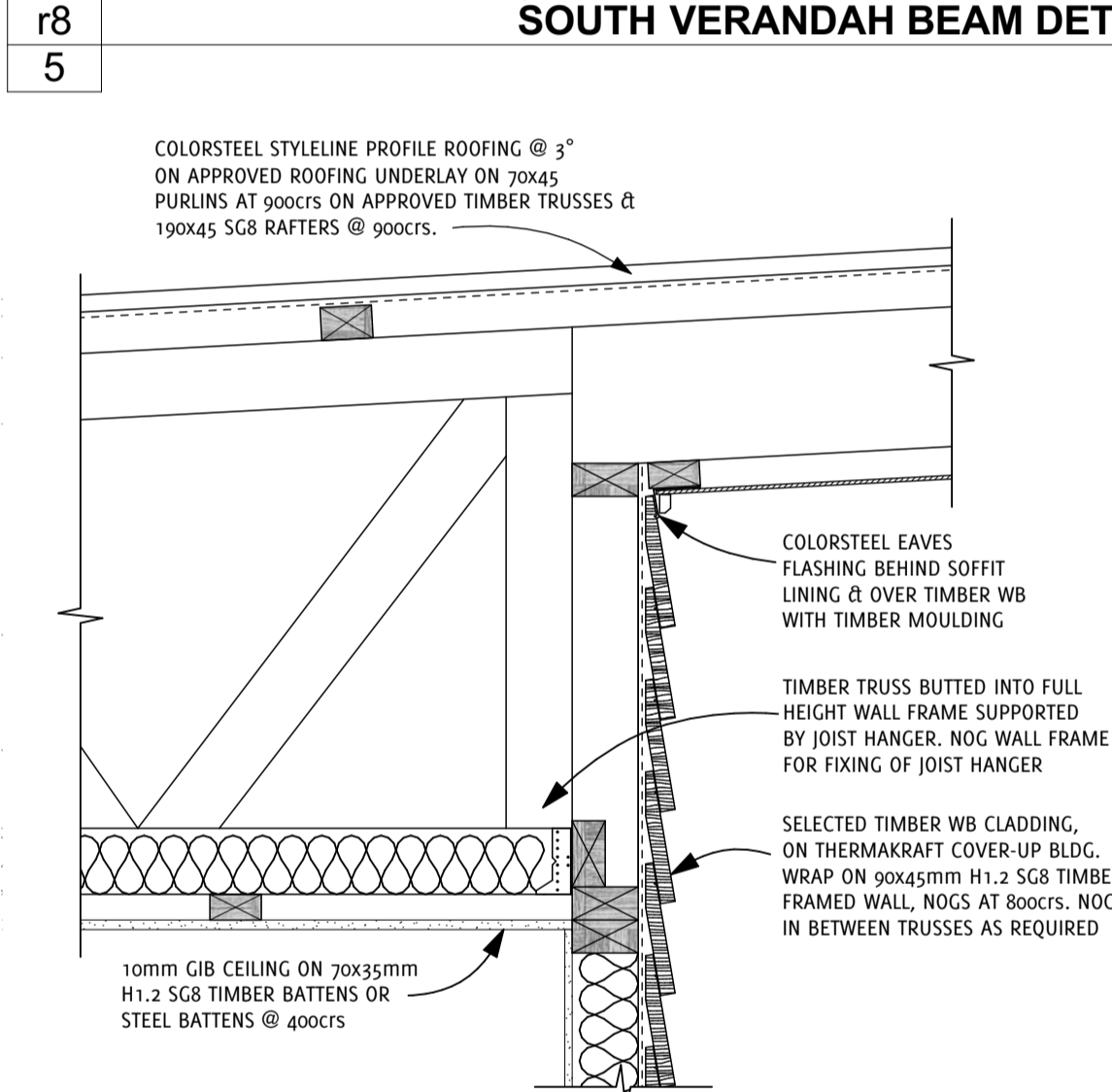

r7
5
NORTH DECK RAFTER/TRUSS DETAIL
1:10

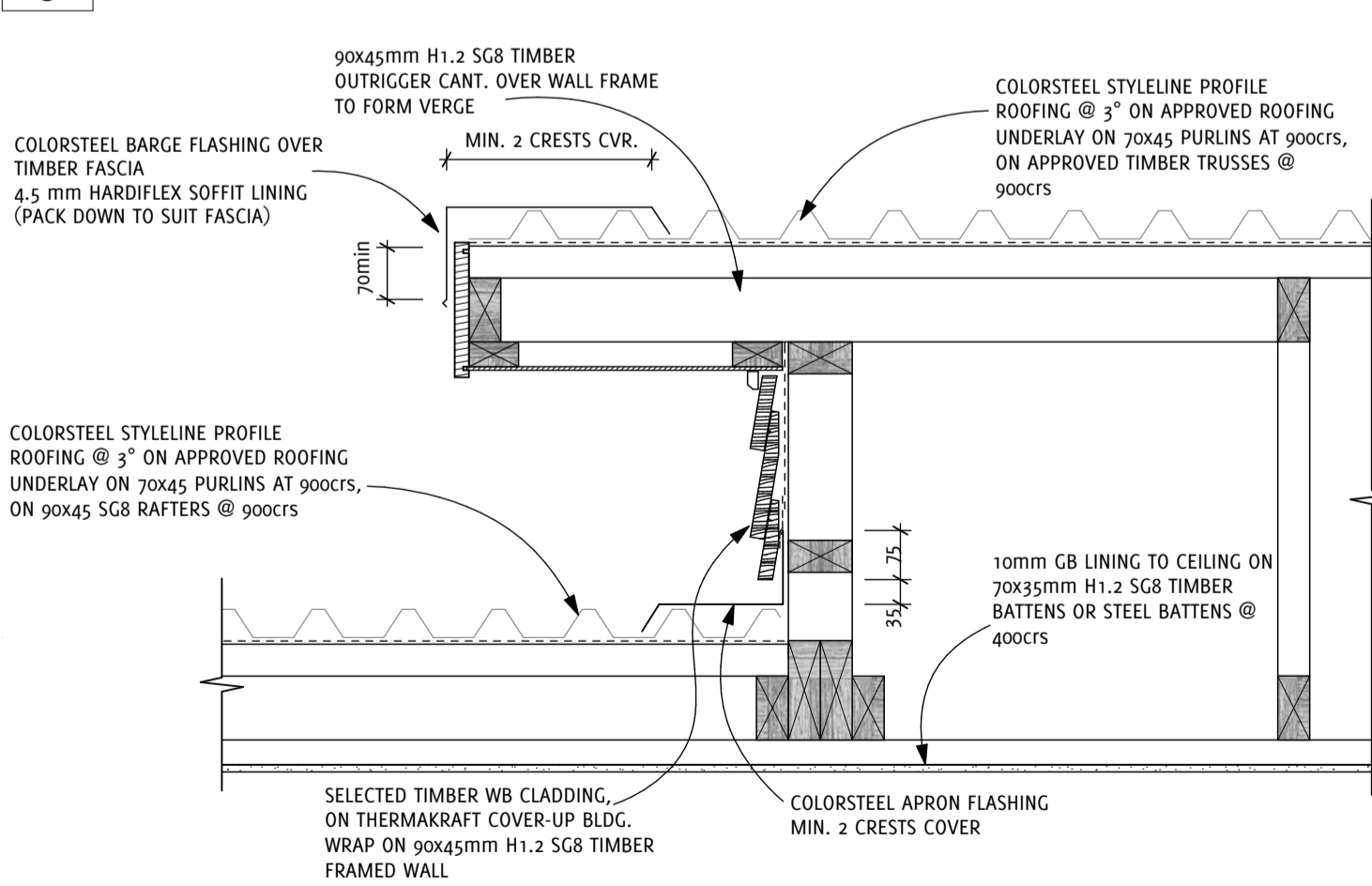

r10
5
VERGE/APRON DETAIL
1:10

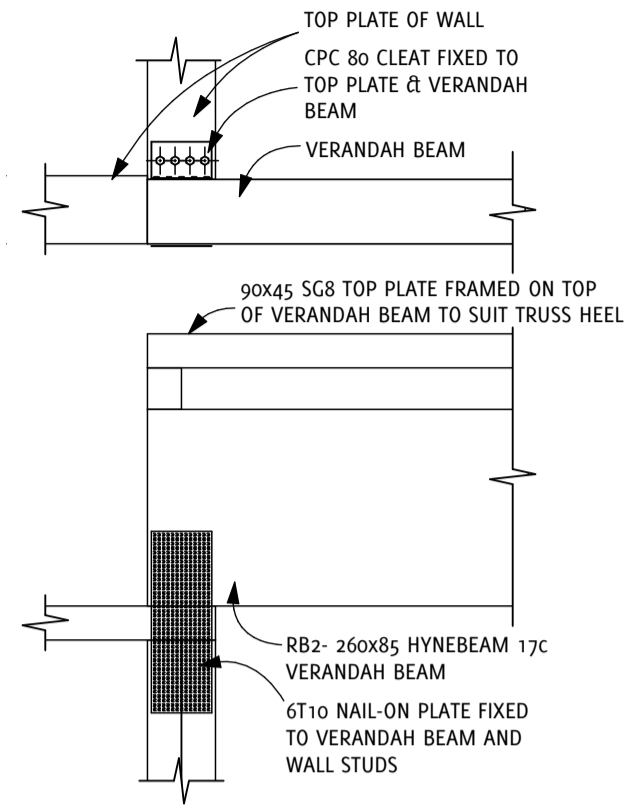

r6
5
BEAM FIXING DETAIL
1:10

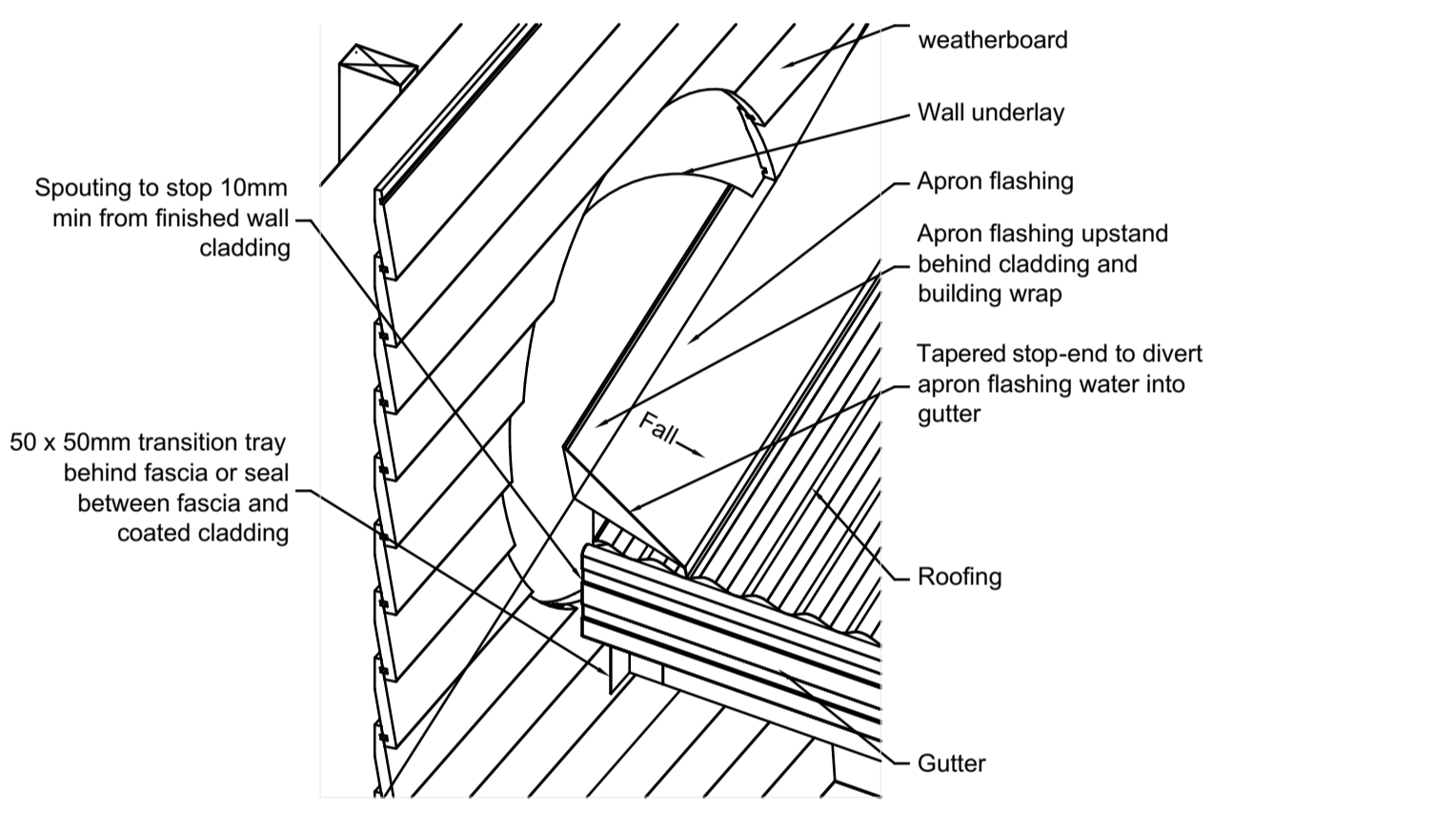

r11
5
APRON FLASHING DETAIL
1:10

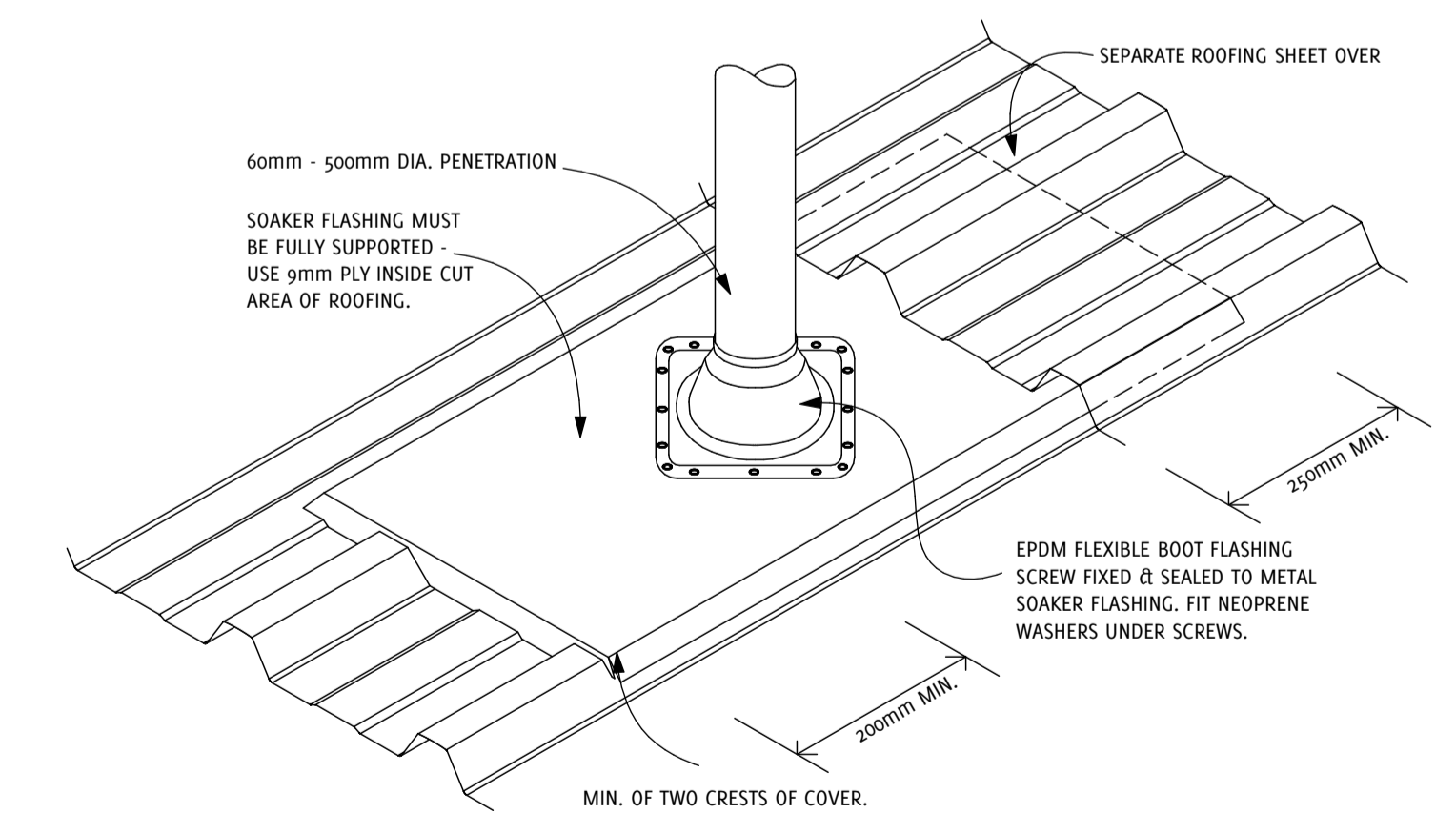

r1
5
PIPE PENETRATION DETAIL
1:10

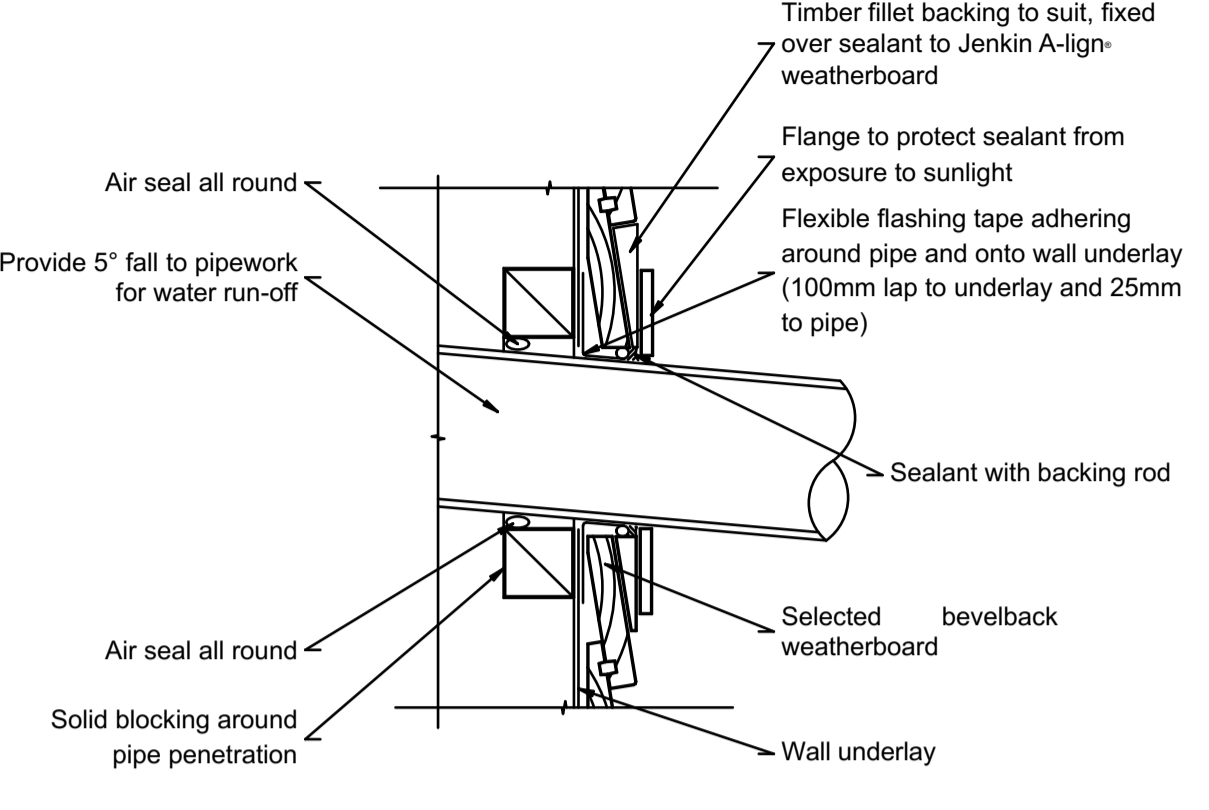

c7
2
PIPE PENETRATION DETAIL
1:5

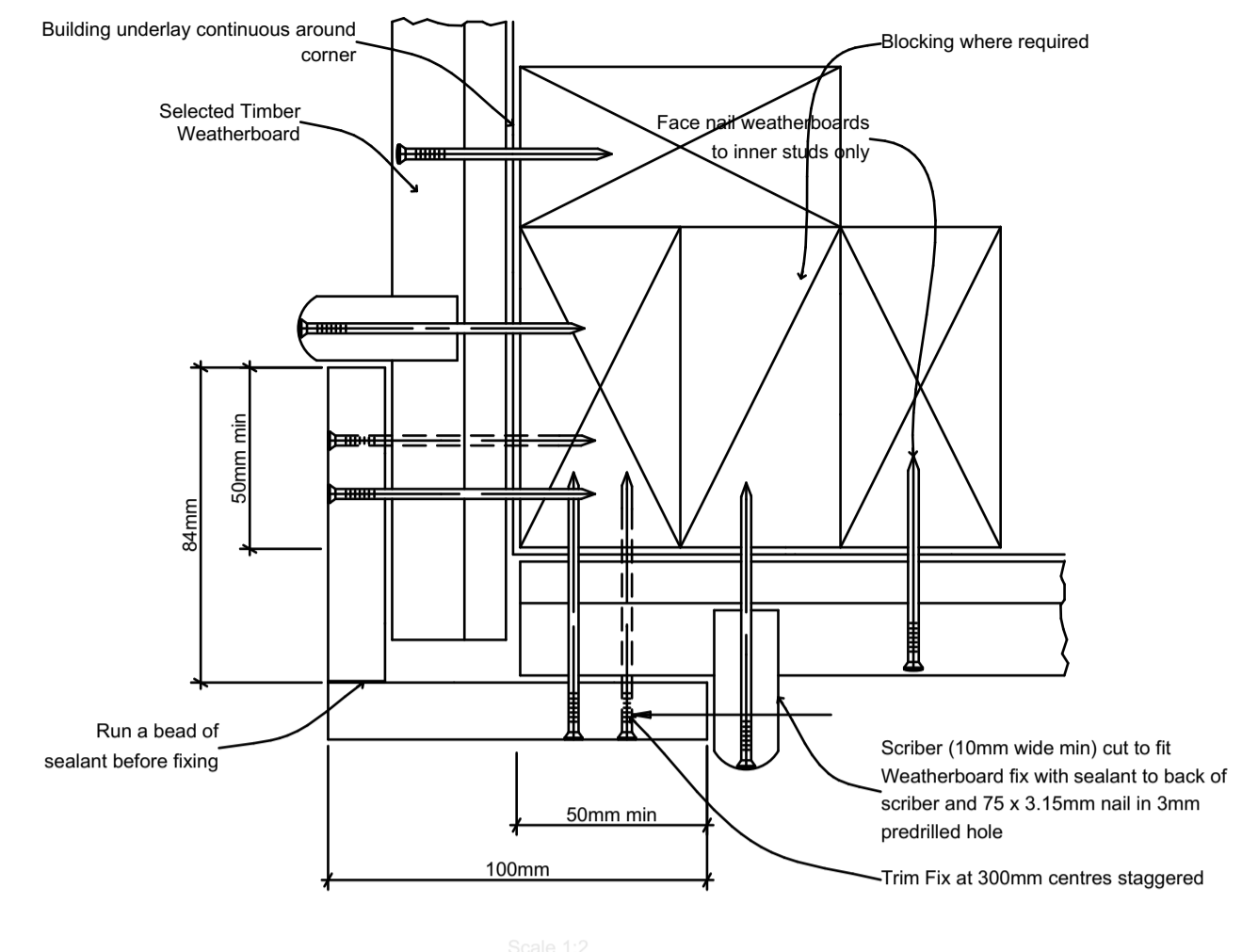

c5
1
EXT. CNR. DETAIL
1:2

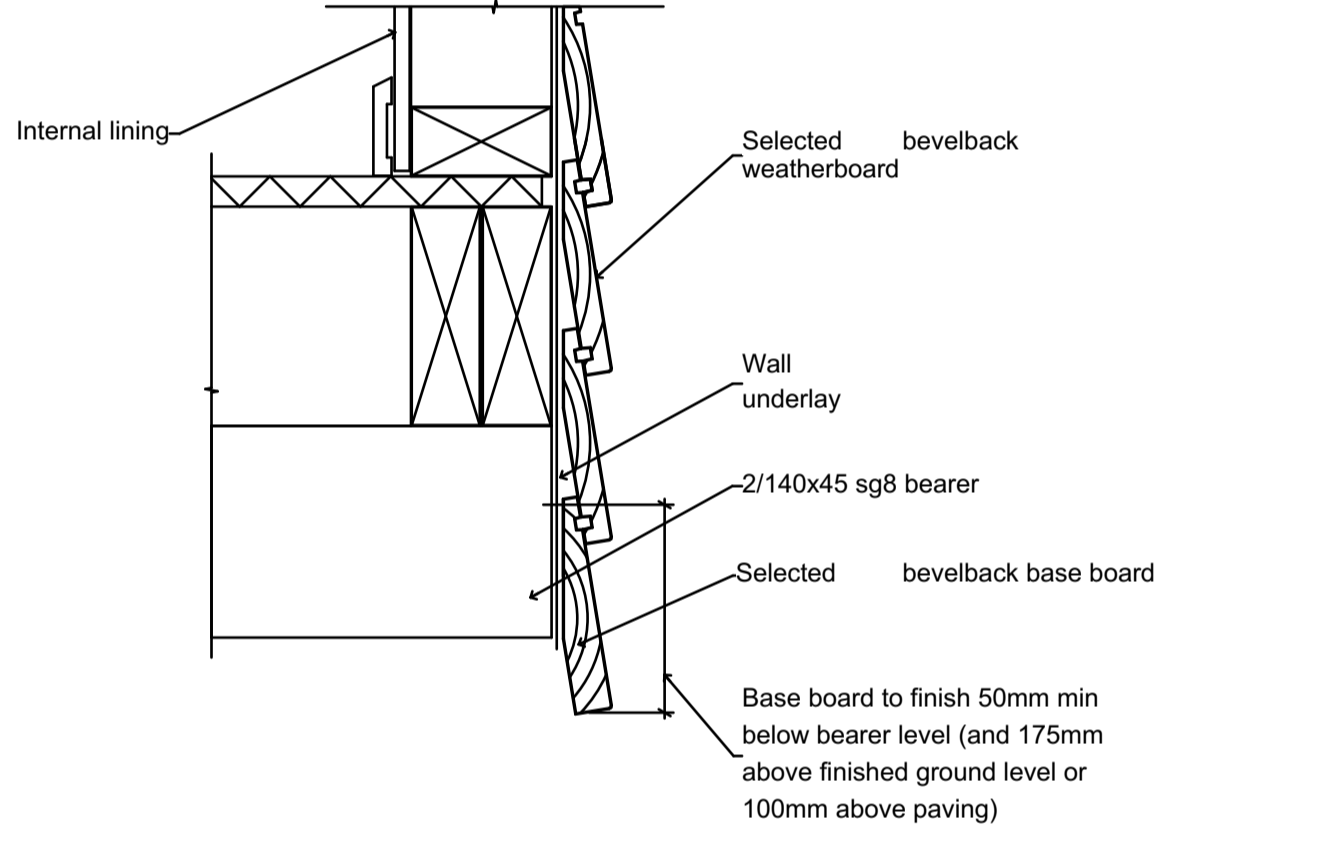

c2
1
BASE DETAIL
1:5

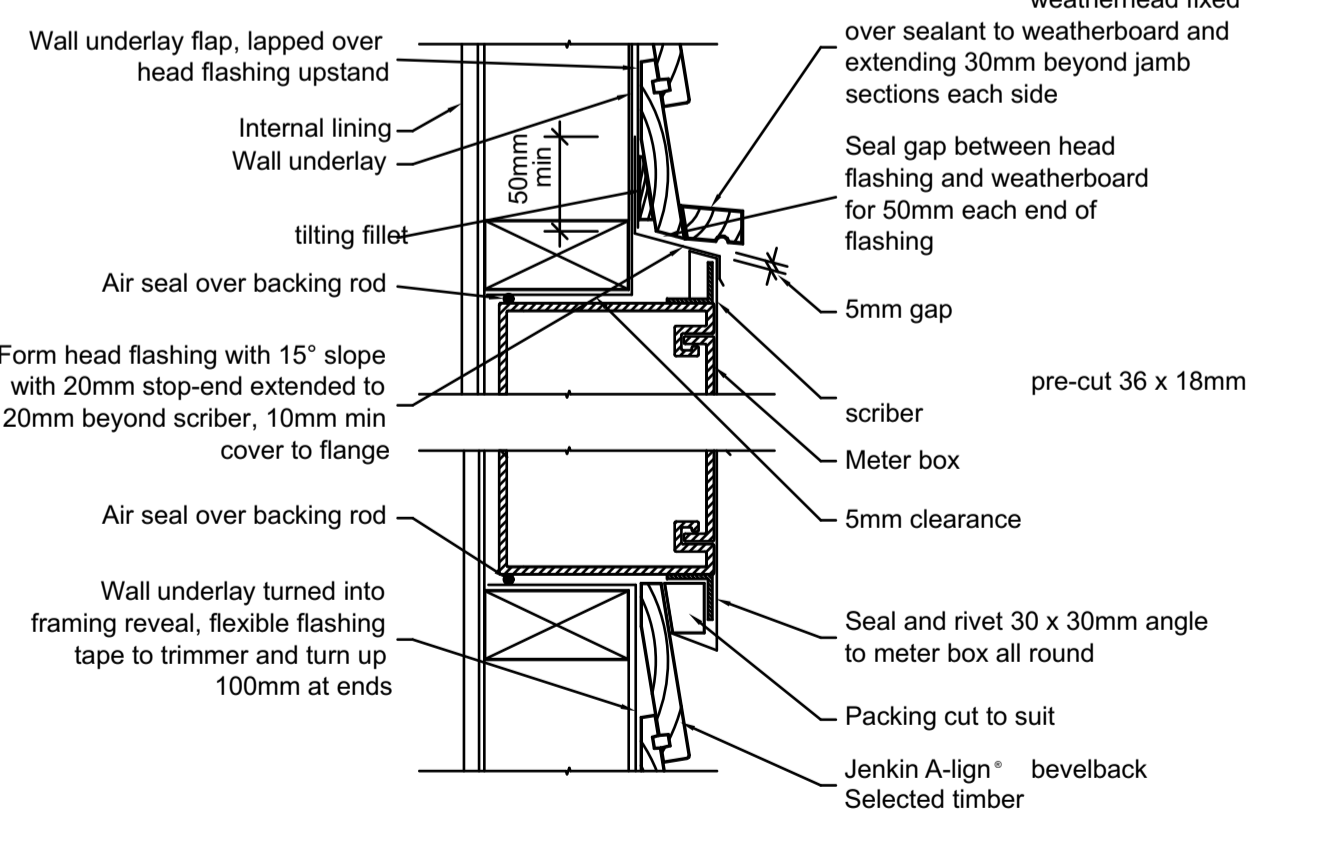

c4
1
METERBOX FLASHING DETAIL
1:5

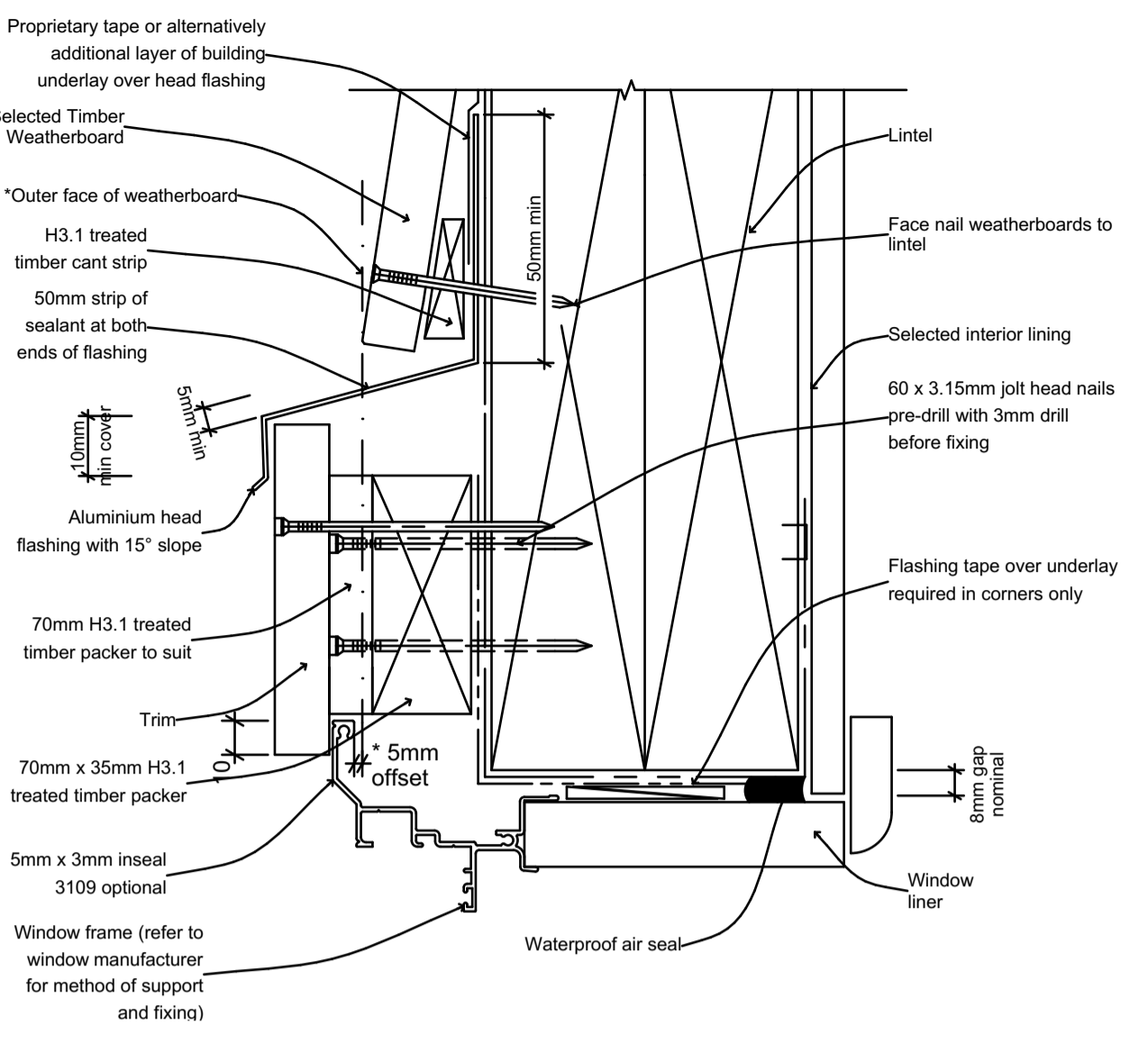

c1
1
WINDOW HEAD DETAIL
1:2

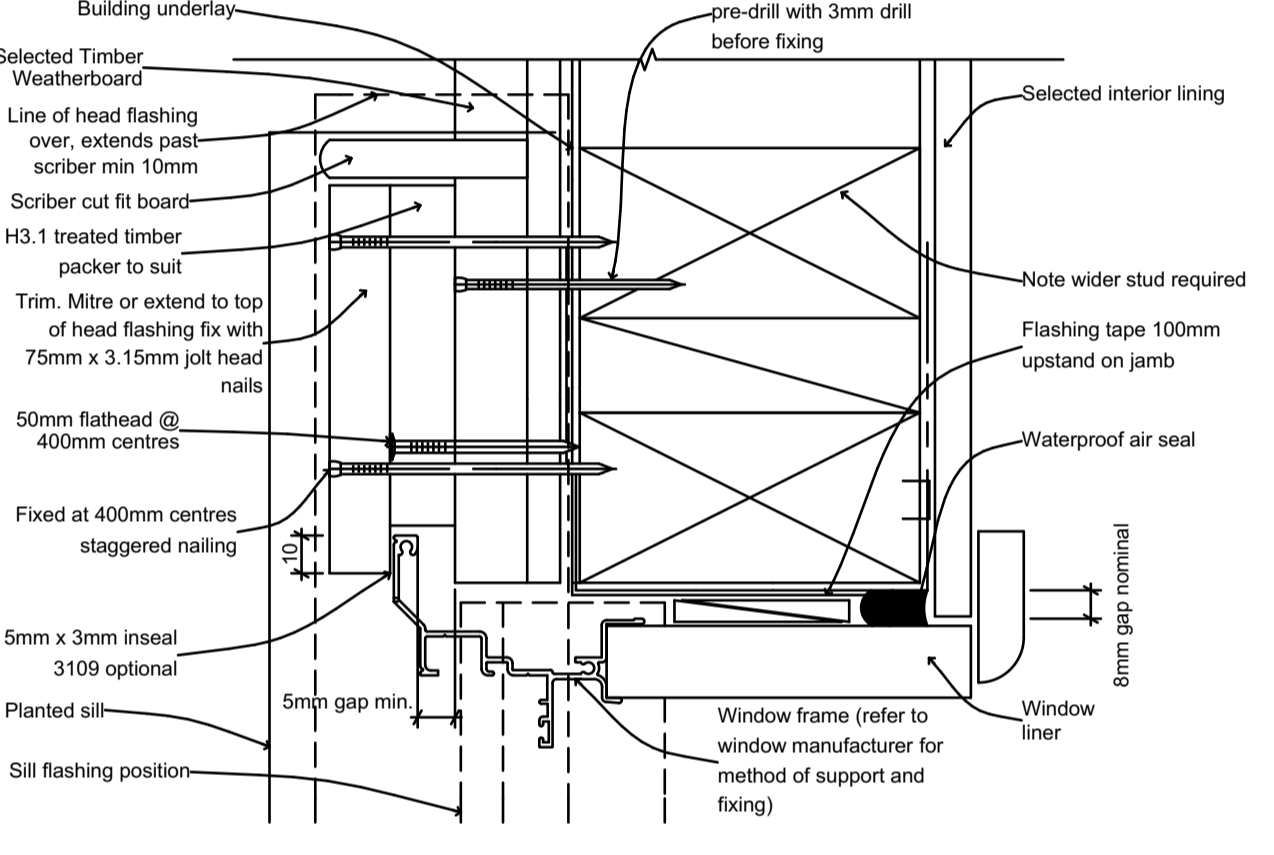

c2
1
WINDOW JAMB DETAIL
1:2

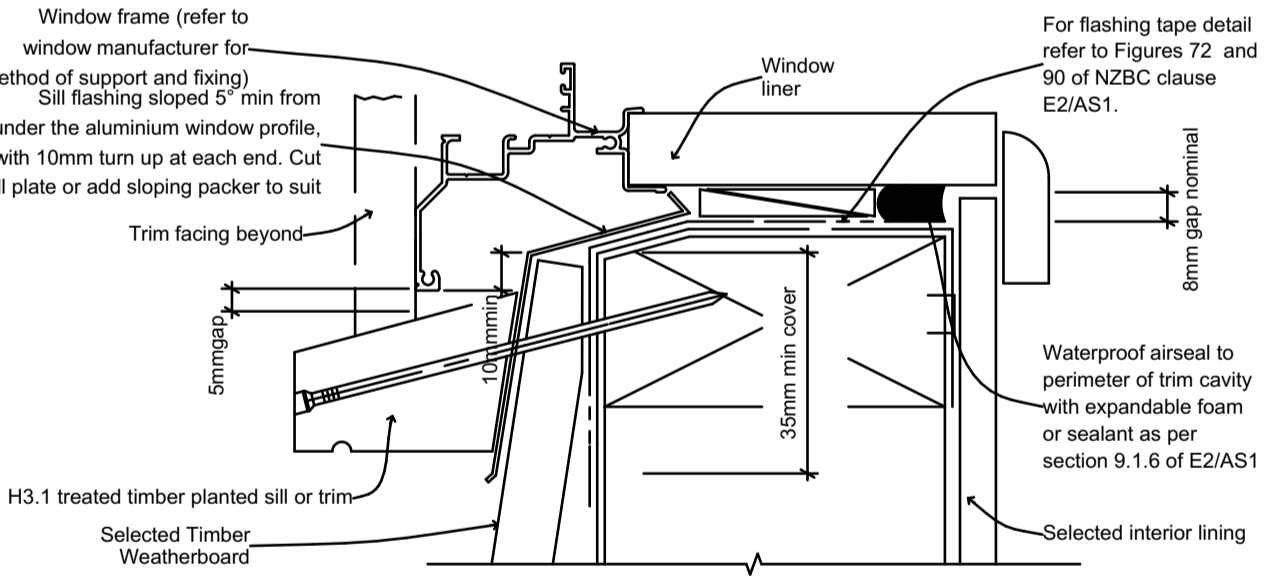

c3
1
WINDOW SILL DETAIL
1:2

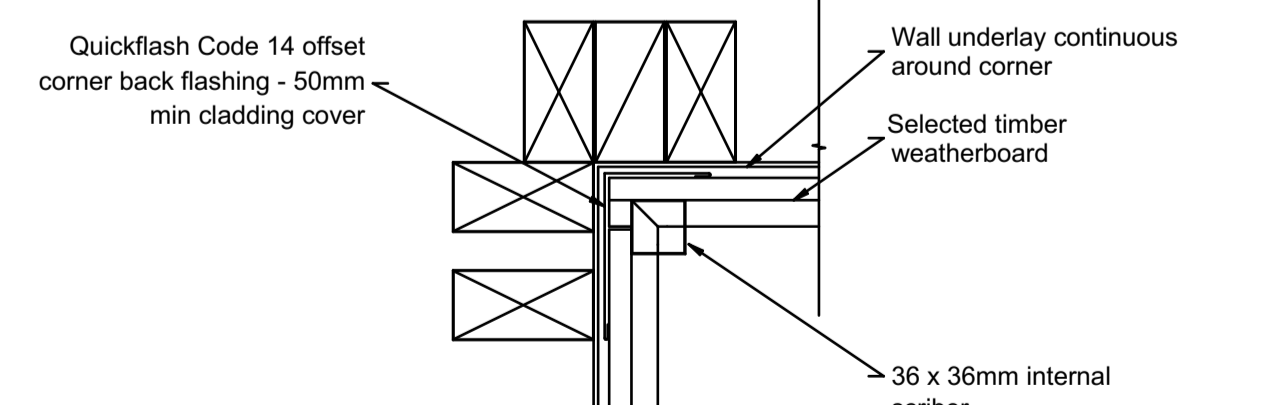

c6
2
INT. CNR. DETAIL
1:5

No.	Date	REVISION	By	No.	Date	ISSUE	By
A	3/4/2013	DIRECT FIX DETAILS		4	27/02/2013	BUILDING CONSENT	JH
				3	12/11/2012	PRELIMINARY COSTING	PT
				2	01/11/2012	SCHEME PLAN 2	PT
				1	20/10/2012	SCHEME PLAN 1	PT



Copyright of this design remains the property of Blank Space Architectural Limited

Project Name
PROPOSED ADDITIONS & ALTERATIONS TO EXISTING RESIDENCE

Project Address
3 KARAKA ROAD KAWAKAWA BAY

Client Name
Mr. G. SUMMERVILLE & Ms. A THOMSON

BLANK SPACE ARCHITECTURAL LIMITED

Drawing Status
CONSENT ISSUE

Sheet Contents
ROOF & CLADDING DETAILS

ORIGINAL DRAWING AT A1 SIZE
A3 REDUCTION: 50%

Drawing No.
6

Rev
B

Drawn By | JH
Checked By | PT

Dwg Date: | 27/02/2013
Plot Date: | 09/02/2013

Project Ref
12-200

OF **6**

T: 09 238 1453 M: 0274 2000 37 E: info@blankspace.co.nz

Code compliance certificate

Section 95, Building Act 2004
(Form 7 – Building (Forms) Regulations 2004)



THE BUILDING

Building consent number:	20130474, 20130474A1	Date building consent issued:	12/06/2014
Street address of building:	3 KARAKA RD KAWAKAWA BAY 2585		
Legal description of land where building is located:	PT LOT 13 DP 23811		
Building name:			
Location of building within site/block number:		Level or unit number:	
Currently, lawfully established use: [include number of occupants per level and per use if more than 1]	Housing		
Year first constructed:	1960s		

THE OWNER

Name of owner:	ALENE FAY THOMSON, GERALD PAUL SUMMERVILLE		
*Contact person:			
Mailing address:	3 Karaka Road, Kawakawa Bay, Papakura 2585		
Street address/ Registered office:			
Phone Number:	Landline:	Mobile:	021 618 455
Daytime:	After hours:	Facsimile No:	
Email address:	paulsummer49@gmail.com		
Website:			

FIRST POINT OF CONTACT FOR COMMUNICATION (Must be in New Zealand)

Full name:	Compass Building Consultants		
Mailing address:	P O Box 217 012 Botany Junction Manukau 213		
Street address/ Registered office:	Unit 23/2 Bishop Dunn Place Botany South Manukau 213		
Phone Number:	Landline:	Mobile:	
Daytime:	09 272 2269	After hours:	Facsimile No: 09 272 2270
Email address:	www.compassbuilding.co.nz		

Code compliance certificate

Section 95, Building Act 2004
(Form 7 – Building (Forms) Regulations 2004)



BUILDING WORK

The following building work is authorised by this building consent:

Dwelling addition and alterations./AMEND: Configuration of extg floor plan & proposed addition, including bathroom, kitchen positions & all assoc. drainage. Add two water storage tanks.

CODE COMPLIANCE

The building consent authority named below is satisfied, on reasonable grounds, that:

√ The building work complies with the building consent;

ATTACHMENTS

On behalf of Auckland Council:

Date issued:

16/11/2015

Print name:

Ian McCormick

Position:

Manager, Building Control

Auckland Council, Private Bag 92300, Auckland 1142

AGREEMENT FOR SALE AND PURCHASE OF REAL ESTATE

This form is approved by the Real Estate Institute of New Zealand Incorporated and by Auckland District Law Society Incorporated.

DATE:

VENDOR: Russell Mark Constant and Rozlyn Ann Constant

PURCHASER:

and/or nominee

The vendor is registered under the GST Act in respect of the transaction evidenced by this agreement and/or will be so registered at settlement:	Yes/No
--	---------------

PROPERTY

Address: 3 Karaka Road, Kawakawa Bay, Auckland

Estate:	FEE SIMPLE	LEASEHOLD	STRATUM IN FREEHOLD	STRATUM IN LEASEHOLD
	GROSSLEASE (FEE SIMPLE)		GROSSLEASE (LEASEHOLD)	(fee simple if none is deleted)

Legal Description:

Area (more or less): 950 square metres more or less	Lot/Flat/Unit: Part Lot 13	DP: 23811	Record of Title (unique identifier): NA93C/461
---	--------------------------------------	---------------------	--

PAYMENT OF PURCHASE PRICE

Purchase price: \$

~~Plus GST (if any)~~ OR **Inclusive of GST (if any)**
If neither is deleted, the purchase price includes GST (if any).

GST date (refer clause 14.0):

Deposit (refer clause 2.0): \$ _____ 10% Payable to Bayleys Real Estate Limited

Balance of purchase price to be paid or satisfied as follows:

(1) By payment in cleared funds on the settlement date which is

OR

~~(2) In the manner described in the Further Terms of Sale.~~

Interest rate for late settlement: 14% p.a.

CONDITIONS (refer clause 10.0)

Finance condition

LIM required: (refer clause 10.2) Yes/No

Lender:

Building report required: (refer clause 10.3) Yes/No

Amount required: SUFFICIENT TO COMPLETE THE TRANSACTION

OIA Consent required: (refer clause 10.4) Yes/No

Finance date: 5 working days from acceptance

Land Act/OIA date:

TENANCIES (if any)

Name of tenant: VACANT POSSESSION

Bond:

Rent:

Term:

Right of renewal:

SALE BY:

Bayleys Real Estate Limited - Manukau Residential

a Member of the Bayleys Realty Group

2 Harris Road

East Tamaki

AUCKLAND 2013

Ph: 09 534 5189

Manager: Alan Owens

Salesperson: Clare Nicholson

alan.owens@bayleys.co.nz

Licensed Real Estate Agent under Real Estate Agents Act 2008

It is agreed that the vendor sells and the purchaser purchases the property, and the chattels listed in Schedule 2, on the terms set out above and in the General Terms of Sale and any Further Terms of Sale.

Release date: 12 November 2018

© AUCKLAND DISTRICT LAW SOCIETY INC. & REAL ESTATE INSTITUTE OF NEW ZEALAND INC. 2018. All Rights Reserved. See full terms of copyright on page 13.

GENERAL TERMS OF SALE

1.0 Definitions, time for performance, notices, and interpretation

1.1 Definitions

- (1) Unless the context requires a different interpretation, words and phrases not otherwise defined have the same meanings ascribed to those words and phrases in the Goods and Services Tax Act 1985, the Property Law Act 2007, the Resource Management Act 1991 or the Unit Titles Act 2010.
- (2) "Agreement" means this document including the front page, these General Terms of Sale, any Further Terms of Sale, and any schedules and attachments.
- (3) "Building Act" means the Building Act 1991 and/or the Building Act 2004.
- (4) "Building warrant of fitness" means a building warrant of fitness supplied to a territorial authority under the Building Act.
- (5) "Cleared funds" means:
 - (a) An electronic transfer of funds that has been made strictly in accordance with the requirements set out in the PLS Guidelines; or
 - (b) A bank cheque, but only in the circumstances permitted by the PLS Guidelines and only if it has been paid strictly in accordance with the requirements set out in the PLS Guidelines.
- (6) "Default GST" means any additional GST, penalty (civil or otherwise), interest, or other sum imposed on the vendor (or where the vendor is or was a member of a GST group its representative member) under the GST Act or the Tax Administration Act 1994 by reason of non-payment of any GST payable in respect of the supply made under this agreement but does not include any such sum levied against the vendor (or where the vendor is or was a member of a GST group its representative member) by reason of a default or delay by the vendor after payment of the GST to the vendor by the purchaser.
- (7) "Electronic instrument" has the same meaning as ascribed to that term in the Land Transfer Act 2017.
- (8) "GST" means Goods and Services Tax arising pursuant to the Goods and Services Tax Act 1985 and "GST Act" means the Goods and Services Tax Act 1985.
- (9) "Landonline Workspace" means an electronic workspace facility approved by the Registrar-General of Land pursuant to the provisions of the Land Transfer Act 2017.
- (10) "LIM" means a land information memorandum issued pursuant to the Local Government Official Information and Meetings Act 1987.
- (11) "LINZ" means Land Information New Zealand.
- (12) "Local authority" means a territorial authority or a regional council.
- (13) "OIA Consent" means consent to purchase the property under the Overseas Investment Act 2005.
- (14) "PLS Guidelines" means the most recent edition, as at the date of this agreement, of the Property Transactions and E-Dealing Practice Guidelines prepared by the Property Law Section of the New Zealand Law Society.
- (15) "Property" means the property described in this agreement.
- (16) "Purchase price" means the total purchase price stated in this agreement which the purchaser has agreed to pay the vendor for the property and the chattels included in the sale.
- (17) "Regional council" means a regional council within the meaning of the Local Government Act 2002.
- (18) "Remote settlement" means settlement of the sale and purchase of the property by way of the purchaser's lawyer paying the moneys due and payable on the settlement date directly into the trust account of the vendor's lawyer, in consideration of the vendor agreeing to meet the vendor's obligations under subclause 3.8(2), pursuant to the protocol for remote settlement recommended in the PLS Guidelines.
- (19) "Residential (but not otherwise sensitive) land" has the meaning ascribed to that term in the Overseas Investment Act 2005.
- (20) "Secure web document exchange" means an electronic messaging service enabling messages and electronic documents to be posted by one party to a secure website to be viewed by the other party immediately after posting.
- (21) "Settlement date" means the date specified as such in this agreement.
- (22) "Settlement statement" means a statement showing the purchase price, plus any GST payable by the purchaser in addition to the purchase price, less any deposit or other payments or allowances to be credited to the purchaser, together with apportionments of all incomings and outgoings apportioned at the settlement date.
- (23) "Territorial authority" means a territorial authority within the meaning of the Local Government Act 2002.
- (24) "Unit title" means a unit title under the Unit Titles Act 2010.
- (25) The terms "principal unit", "accessory unit", "owner", "unit plan", and "unit" have the meanings ascribed to those terms in the Unit Titles Act 2010.
- (26) The term "rules" includes both body corporate rules under the Unit Titles Act 1972 and body corporate operational rules under the Unit Titles Act 2010.
- (27) The terms "building", "building consent", "code compliance certificate", "compliance schedule", "household unit", and "commercial on-seller" have the meanings ascribed to those terms in the Building Act.
- (28) The term "title" includes where appropriate a record of title within the meaning of the Land Transfer Act 2017.
- (29) The terms "going concern", "goods", "principal place of residence", "recipient", "registered person", "registration number", "supply", and "taxable activity" have the meanings ascribed to those terms in the GST Act.
- (30) The terms "tax information" and "tax statement" have the meanings ascribed to those terms in the Land Transfer Act 2017.
- (31) The terms "associated person", "conveyancer", "residential land purchase amount", "offshore RLWT person", "RLWT", "RLWT certificate of exemption" and "RLWT rules" have the meanings ascribed to those terms in the Income Tax Act 2007.
- (32) The term "Commissioner" has the meaning ascribed to that term in the Tax Administration Act 1994.
- (33) "Working day" means any day of the week other than:
 - (a) Saturday, Sunday, Waitangi Day, Good Friday, Easter Monday, Anzac Day, the Sovereign's Birthday, and Labour Day;
 - (b) if Waitangi Day or Anzac Day falls on a Saturday or Sunday, the following Monday;
 - (c) a day in the period commencing on the 24th day of December in any year and ending on the 5th day of January (or in the case of subclause 10.2(2) the 15th day of January) in the following year, both days inclusive; and
 - (d) the day observed as the anniversary of any province in which the property is situated.
 A working day shall be deemed to commence at 9.00 am and to terminate at 5.00 pm.
- (34) Unless a contrary intention appears on the front page or elsewhere in this agreement:
 - (a) the interest rate for late settlement is equivalent to the interest rate charged by the Inland Revenue Department on unpaid tax under the Tax Administration Act 1994 during the period for which the interest rate for late settlement is payable, plus 5% per annum; and
 - (b) a party is in default if it did not do what it has contracted to do to enable settlement to occur, regardless of the cause of such failure.

1.2 Time for Performance

- (1) Where the day nominated for settlement or the fulfilment of a condition is not a working day, then the settlement date or the date for fulfilment of the condition shall be the last working day before the day so nominated.
- (2) Any act done pursuant to this agreement by a party, including service of notices, after 5.00 pm on a working day, or on a day that is not a working day, shall be deemed to have been done at 9.00 am on the next succeeding working day.
- (3) Where two or more acts done pursuant to this agreement, including service of notices, are deemed to have been done at the same time, they shall take effect in the order in which they would have taken effect but for subclause 1.2(2).

1.3 Notices

The following apply to all notices between the parties relevant to this agreement, whether authorised by this agreement or by the general law:

- (1) All notices must be served in writing.
- (2) Any notice under section 28 of the Property Law Act 2007, where the purchaser is in possession of the property, must be served in accordance with section 353 of that Act.
- (3) All other notices, unless otherwise required by the Property Law Act 2007, must be served by one of the following means:
 - (a) on the party as authorised by sections 354 to 361 of the Property Law Act 2007, or
 - (b) on the party or on the party's lawyer:
 - (i) by personal delivery; or
 - (ii) by posting by ordinary mail; or
 - (iii) by facsimile; or
 - (iv) by email; or
 - (v) in the case of the party's lawyer only, by sending by document exchange or, if both parties' lawyers have agreed to subscribe to the same secure web document exchange for this agreement, by secure web document exchange.
- (4) In respect of the means of service specified in subclause 1.3(3)(b), a notice is deemed to have been served:
 - (a) in the case of personal delivery, when received by the party or at the lawyer's office;
 - (b) in the case of posting by ordinary mail, on the third working day following the date of posting to the address for service notified in writing by the party or to the postal address of the lawyer's office;
 - (c) in the case of facsimile transmission, when sent to the facsimile number notified in writing by the party or to the facsimile number of the lawyer's office;
 - (d) in the case of email, when acknowledged by the party or by the lawyer orally or by return email or otherwise in writing, except that return emails generated automatically shall not constitute an acknowledgement;
 - (e) in the case of sending by document exchange, on the second working day following the date of sending to the document exchange number of the lawyer's office;

- (f) in the case of sending by secure web document exchange, at the time when in the ordinary course of operation of that secure web document exchange, a notice posted by one party is accessible for viewing or downloading by the other party.
- (5) Any period of notice required to be given under this agreement shall be computed by excluding the day of service.
- (6) In accordance with section 222 of the Contract and Commercial Law Act 2017, the parties agree that any notice or document that must be given in writing by one party to the other may be given in electronic form and by means of an electronic communication, subject to the rules regarding service set out above.

1.4 Interpretation

- (1) If there is more than one vendor or purchaser, the liability of the vendors or of the purchasers, as the case may be, is joint and several.
- (2) Where the purchaser executes this agreement with provision for a nominee, or as agent for an undisclosed or disclosed but unidentified principal, or on behalf of a company to be formed, the purchaser shall at all times remain liable for all obligations on the part of the purchaser.
- (3) If any inserted term (including any Further Terms of Sale) conflicts with the General Terms of Sale the inserted term shall prevail.
- (4) Headings are for information only and do not form part of this agreement.
- (5) References to statutory provisions shall be construed as references to those provisions as they may be amended or re-enacted or as their application is modified by other provisions from time to time.

2.0 Deposit

- 2.1 The purchaser shall pay the deposit to the vendor or the vendor's agent immediately upon execution of this agreement by both parties and/or at such other time as is specified in this agreement.
- 2.2 If the deposit is not paid on the due date for payment, the vendor may at any time thereafter serve on the purchaser notice requiring payment. If the purchaser fails to pay the deposit on or before the third working day after service of the notice, time being of the essence, the vendor may cancel this agreement by serving notice of cancellation on the purchaser. No notice of cancellation shall be effective if the deposit has been paid before the notice of cancellation is served.
- 2.3 The deposit shall be in part payment of the purchase price.
- 2.4 The person to whom the deposit is paid shall hold it as a stakeholder until:
- (1) the requisition procedure under clause 6.0 is completed without either party cancelling this agreement; and
- (2) where this agreement is entered into subject to any condition(s) expressed in this agreement, each such condition has been fulfilled or waived; and
- (3) where the property is a unit title:
- (a) a pre-settlement disclosure statement, certified correct by the body corporate, under section 147 of the Unit Titles Act 2010; and
- (b) an additional disclosure statement under section 148 of the Unit Titles Act 2010 (if requested by the purchaser within the time prescribed in section 148(2)),
- have been provided to the purchaser by the vendor within the times prescribed in those sections or otherwise the purchaser has given notice under section 149(2) of the Unit Titles Act 2010 to postpone the settlement date until after the disclosure statements have been provided; or
- (4) this agreement is cancelled pursuant to subclause 6.2(3)(c) or avoided pursuant to subclause 10.8(5) or, where the property is a unit title and the purchaser having the right to cancel this agreement pursuant to section 151(2) of the Unit Titles Act 2010 has cancelled this agreement pursuant to that section, or has waived the right to cancel by giving notice to the vendor, or by completing settlement of the purchase.

3.0 Possession and Settlement

Possession

- 3.1 Unless particulars of a tenancy are included in this agreement the property is sold with vacant possession and the vendor shall so yield the property on the settlement date.
- 3.2 If the property is sold with vacant possession, then subject to the rights of any tenants of the property, the vendor shall permit the purchaser or any person authorised by the purchaser in writing, upon reasonable notice:
- (1) to enter the property on one occasion prior to the settlement date for the purposes of examining the property, chattels and fixtures which are included in the sale; and
- (2) to re-enter the property on or before the settlement date to confirm compliance by the vendor with any agreement made by the vendor to carry out any work on the property and the chattels and the fixtures.
- 3.3 Possession shall be given and taken on the settlement date. Outgoings and incomings in respect of the settlement date are the responsibility of and belong to the vendor.
- 3.4 On the settlement date, the vendor shall make available to the purchaser keys to all exterior doors that are locked by key, electronic door openers to all doors that are opened electronically, and the keys and/or security codes to any alarms. The vendor does not have to make available keys, electronic door openers, and security codes where the property is tenanted and these are held by the tenant.

Settlement

- 3.5 The vendor shall prepare, at the vendor's own expense, a settlement statement. The vendor shall tender the settlement statement to the purchaser or the purchaser's lawyer a reasonable time prior to the settlement date.
- 3.6 The purchaser's lawyer shall:
- (1) within a reasonable time prior to the settlement date create a Landonline Workspace for the transaction, notify the vendor's lawyer of the dealing number allocated by LINZ, and prepare in that workspace a transfer instrument in respect of the property; and
- (2) prior to settlement:
- (a) lodge in that workspace the tax information contained in the transferee's tax statement; and
- (b) certify and sign the transfer instrument.
- 3.7 The vendor's lawyer shall:
- (1) within a reasonable time prior to the settlement date prepare in that workspace all other electronic instruments required to confer title on the purchaser in terms of the vendor's obligations under this agreement; and
- (2) prior to settlement:
- (a) lodge in that workspace the tax information contained in the transferor's tax statement; and
- (b) have those instruments and the transfer instrument certified, signed and, where possible, pre-validated.
- 3.8 On the settlement date:
- (1) the balance of the purchase price, interest and other moneys, if any, shall be paid by the purchaser in cleared funds or otherwise satisfied as provided in this agreement (credit being given for any amount payable by the vendor under subclause 3.12 or 3.14);
- (2) the vendor's lawyer shall immediately thereafter:
- (a) release or procure the release of the transfer instrument and the other instruments mentioned in subclause 3.7(1) so that the purchaser's lawyer can then submit them for registration;
- (b) pay to the purchaser's lawyer the LINZ registration fees on all of the instruments mentioned in subclause 3.7(1), unless these fees will be invoiced to the vendor's lawyer by LINZ directly; and
- (c) deliver to the purchaser's lawyer any other documents that the vendor must provide to the purchaser on settlement in terms of this agreement.
- 3.9 All obligations under subclause 3.8 are interdependent.
- 3.10 The parties shall complete settlement by way of remote settlement, provided that where payment by bank cheque is permitted under the PLS Guidelines, payment may be made by the personal delivery of a bank cheque to the vendor's lawyer's office, so long as it is accompanied by the undertaking from the purchaser's lawyer required by those Guidelines.

Last Minute Settlement

- 3.11 If due to the delay of the purchaser, settlement takes place between 4.00 pm and 5.00 pm on the settlement date ("last minute settlement"), the purchaser shall pay the vendor:
- (1) one day's interest at the interest rate for late settlement on the portion of the purchase price paid in the last minute settlement; and
- (2) if the day following the last minute settlement is not a working day, an additional day's interest (calculated in the same manner) for each day until, but excluding, the next working day.

Purchaser Default: Late Settlement

- 3.12 If any portion of the purchase price is not paid upon the due date for payment, then, provided that the vendor provides reasonable evidence of the vendor's ability to perform any obligation the vendor is obliged to perform on that date in consideration for such payment:
- (1) the purchaser shall pay to the vendor interest at the interest rate for late settlement on the portion of the purchase price so unpaid for the period from the due date for payment until payment ("the default period"); but nevertheless, this stipulation is without prejudice to any of the vendor's rights or remedies including any right to claim for additional expenses and damages. For the purposes of this subclause, a payment made on a day other than a working day or after the termination of a working day shall be deemed to be made on the next following working day and interest shall be computed accordingly; and
 - (2) the vendor is not obliged to give the purchaser possession of the property or to pay the purchaser any amount for remaining in possession, unless this agreement relates to a tenanted property, in which case the vendor must elect either to:
 - (a) account to the purchaser on settlement for incomings in respect of the property which are payable and received during the default period, in which event the purchaser shall be responsible for the outgoings relating to the property during the default period; or
 - (b) retain such incomings in lieu of receiving interest from the purchaser pursuant to subclause 3.12(1).
- 3.13 Where subclause 3.12(1) applies and the parties are unable to agree upon any amount claimed by the vendor for additional expenses and damages:
- (1) an interim amount shall on settlement be paid to a stakeholder by the purchaser until the amount payable is determined;
 - (2) the interim amount must be a reasonable sum having regard to all of the circumstances;
 - (3) if the parties cannot agree on the interim amount, the interim amount shall be determined by an experienced property lawyer appointed by the parties. The appointee's costs shall be met equally by the parties. If the parties cannot agree on the appointee, the appointment shall be made on the application of either party by the president for the time being of the New Zealand Law Society;
 - (4) the stakeholder shall lodge the interim amount on interest-bearing call deposit with a bank registered under the Reserve Bank of New Zealand Act 1989 in the joint names of the vendor and the purchaser;
 - (5) the interest earned on the interim amount net of any withholding tax and any bank or legal administration fees and commission charges shall follow the destination of the interim amount;
 - (6) the amount determined to be payable shall not be limited by the interim amount; and
 - (7) if the parties cannot agree on a stakeholder, the interim amount shall be paid to a stakeholder nominated on the application of either party by the president for the time being of the New Zealand Law Society.

Vendor Default: Late Settlement or Failure to Give Possession

- 3.14 (1) For the purposes of this subclause 3.14:
- (a) the default period means:
 - (i) in subclause 3.14(2), the period from the settlement date until the date when the vendor is able and willing to provide vacant possession and the purchaser takes possession; and
 - (ii) in subclause 3.14(3), the period from the date the purchaser takes possession until the date when settlement occurs; and
 - (iii) in subclause 3.14(5), the period from the settlement date until the date when settlement occurs; and
 - (b) the vendor shall be deemed to be unwilling to give possession if the vendor does not offer to give possession.
- (2) If this agreement provides for vacant possession but the vendor is unable or unwilling to give vacant possession on the settlement date, then, provided that the purchaser provides reasonable evidence of the purchaser's ability to perform the purchaser's obligations under this agreement:
- (a) the vendor shall pay the purchaser, at the purchaser's election, either:
 - (i) compensation for any reasonable costs incurred for temporary accommodation for persons and storage of chattels during the default period; or
 - (ii) an amount equivalent to interest at the interest rate for late settlement on the entire purchase price during the default period; and
 - (b) the purchaser shall pay the vendor an amount equivalent to the interest earned or which would be earned on overnight deposits lodged in the purchaser's lawyer's trust bank account on such portion of the purchase price (including any deposit) as is payable under this agreement on or by the settlement date but remains unpaid during the default period less:
 - (i) any withholding tax; and
 - (ii) any bank or legal administration fees and commission charges; and
 - (iii) any interest payable by the purchaser to the purchaser's lender during the default period in respect of any mortgage or loan taken out by the purchaser in relation to the purchase of the property.
- (3) If this agreement provides for vacant possession and the vendor is able and willing to give vacant possession on the settlement date, then, provided the purchaser provides reasonable evidence of the purchaser's ability to perform the purchaser's obligations under this agreement, the purchaser may elect to take possession in which case the vendor shall not be liable to pay any interest or other moneys to the purchaser but the purchaser shall pay the vendor the same amount as that specified in subclause 3.14(2)(b) during the default period. A purchaser in possession under this subclause 3.14(3) is a licensee only.
- (4) Notwithstanding the provisions of subclause 3.14(3), the purchaser may elect not to take possession when the purchaser is entitled to take it. If the purchaser elects not to take possession, the provisions of subclause 3.14(2) shall apply as though the vendor were unable or unwilling to give vacant possession on the settlement date.
- (5) If this agreement provides for the property to be sold tenanted then, provided that the purchaser provides reasonable evidence of the purchaser's ability to perform the purchaser's obligations under this agreement, the vendor shall on settlement account to the purchaser for incomings which are payable and received in respect of the property during the default period less the outgoings paid by the vendor during that period. Apart from accounting for such incomings, the vendor shall not be liable to pay any other moneys to the purchaser but the purchaser shall pay the vendor the same amount as that specified in subclause 3.14(2)(b) during the default period.
- (6) The provisions of this subclause 3.14 shall be without prejudice to any of the purchaser's rights or remedies including any right to claim for any additional expenses and damages suffered by the purchaser.
- (7) Where the parties are unable to agree upon any amount payable under this subclause 3.14:
- (a) an interim amount shall on settlement be paid to a stakeholder by the party against whom it is claimed until the amount payable is determined;
 - (b) the interim amount shall be the lower of:
 - (i) the amount claimed; or
 - (ii) an amount equivalent to interest at the interest rate for late settlement for the relevant default period on such portion of the purchase price (including any deposit) as is payable under this agreement on or by the settlement date.
 - (c) the stakeholder shall lodge the interim amount on interest-bearing call deposit with a bank registered under the Reserve Bank of New Zealand Act 1989 in the joint names of the vendor and the purchaser;
 - (d) the interest earned on the interim amount net of any withholding tax and any bank or legal administration fees and commission charges shall follow the destination of the interim amount;
 - (e) the amount determined to be payable shall not be limited by the interim amount; and
 - (f) if the parties cannot agree on a stakeholder the interim amount shall be paid to a stakeholder nominated on the application of either party by the president for the time being of the New Zealand Law Society.

Deferment of Settlement and Possession

- 3.15 If
- (1) this is an agreement for the sale by a commercial on-seller of a household unit; and
 - (2) a code compliance certificate has not been issued by the settlement date in relation to the household unit,
- then, unless the parties agree otherwise (in which case the parties shall enter into a written agreement in the form (if any) prescribed by the Building (Forms) Regulations 2004), the settlement date shall be deferred to the fifth working day following the date upon which the vendor has given the purchaser notice that the code compliance certificate has been issued (which notice must be accompanied by a copy of the certificate).
- 3.16 In every case, if neither party is ready, willing, and able to settle on the settlement date, the settlement date shall be deferred to the third working day following the date upon which one of the parties gives notice it has become ready, willing, and able to settle.
- 3.17 If
- (1) the property is a unit title;
 - (2) the settlement date is deferred pursuant to either subclause 3.15 or subclause 3.16; and
 - (3) the vendor considers on reasonable grounds that an extension of time is necessary or desirable in order for the vendor to comply with the warranty by the vendor in subclause 9.2(3),
- (4) then the vendor may extend the settlement date:
- (a) where there is a deferment of the settlement date pursuant to subclause 3.15, to the tenth working day following the date upon which the vendor gives the purchaser notice that the code compliance certificate has been issued, provided the vendor gives notice of the extension to the purchaser no later than the second working day after such notice; or
 - (b) where there is a deferment of the settlement date pursuant to subclause 3.16, to the tenth working day following the date upon which one of the parties gives notice that it has become ready, willing, and able to settle, provided the vendor gives notice of the extension to the purchaser no later than the second working day after such notice.

New Title Provision

- 3.18 (1) Where
- (a) the transfer of the property is to be registered against a new title yet to be issued; and
 - (b) a search copy, as defined in section 60 of the Land Transfer Act 2017, of that title is not obtainable by the tenth working day prior to the settlement date,
 - (c) then, unless the purchaser elects that settlement shall still take place on the agreed settlement date, the settlement date shall be deferred to the tenth working day following the later of the date on which:
 - (i) the vendor has given the purchaser notice that a search copy is obtainable; or
 - (ii) the requisitions procedure under clause 6.0 is complete.
- (2) Subclause 3.18(1) shall not apply where it is necessary to register the transfer of the property to enable a plan to deposit and title to the property to issue.

4.0 Residential Land Withholding Tax

- 4.1 If the vendor does not have a conveyancer or the vendor and the purchaser are associated persons, then:
- (1) the vendor must provide the purchaser or the purchaser's conveyancer, on or before the second working day before the due date for payment of the first residential land purchase amount payable under this agreement, with:
 - (a) sufficient information to enable the purchaser or the purchaser's conveyancer to determine to their reasonable satisfaction whether section 54C of the Tax Administration Act 1994 applies to the sale of the property; and
 - (b) if the purchaser or the purchaser's conveyancer determines to their reasonable satisfaction that section 54C of the Tax Administration Act 1994 does apply, all of the information required by that section and either an RLWT certificate of exemption in respect of the sale or otherwise such other information that the purchaser or the purchaser's conveyancer may reasonably require to enable the purchaser or the purchaser's conveyancer to determine to their reasonable satisfaction the amount of RLWT that must be withheld from each residential land purchase amount;
 - (2) the vendor shall be liable to pay any costs reasonably incurred by the purchaser or the purchaser's conveyancer in relation to RLWT, including the cost of obtaining professional advice in determining whether there is a requirement to withhold RLWT and the amount of RLWT that must be withheld, if any; and
 - (3) any payments payable by the purchaser on account of the purchase price shall be deemed to have been paid to the extent that:
 - (a) RLWT has been withheld from those payments by the purchaser or the purchaser's conveyancer as required by the RLWT rules; and
 - (b) any costs payable by the vendor under subclause 4.1(2) have been deducted from those payments by the purchaser or the purchaser's conveyancer.
- 4.2 If the vendor does not have a conveyancer or the vendor and the purchaser are associated persons and if the vendor fails to provide the information required under subclause 4.1(1), then the purchaser may:
- (1) defer the payment of the first residential land purchase amount payable under this agreement (and any residential land purchase amount that may subsequently fall due for payment) until such time as the vendor supplies that information; or
 - (2) on the due date for payment of that residential land purchase amount, or at any time thereafter if payment has been deferred by the purchaser pursuant to this subclause and the vendor has still not provided that information, treat the sale of the property as if it is being made by an offshore RLWT person where there is a requirement to pay RLWT.
- 4.3 If pursuant to subclause 4.2 the purchaser treats the sale of the property as if it is being made by an offshore RLWT person where there is a requirement to pay RLWT, the purchaser or the purchaser's conveyancer may:
- (1) make a reasonable assessment of the amount of RLWT that the purchaser or the purchaser's conveyancer would be required by the RLWT rules to withhold from any residential land purchase amount if the sale is treated in that manner; and
 - (2) withhold that amount from any residential land purchase amount and pay it to the Commissioner as RLWT.
- 4.4 Any amount withheld by the purchaser or the purchaser's conveyancer pursuant to subclause 4.3 shall be treated as RLWT that the purchaser or the purchaser's conveyancer is required by the RLWT rules to withhold.
- 4.5 The purchaser or the purchaser's conveyancer shall give notice to the vendor a reasonable time before payment of any sum due to be paid on account of the purchase price of:
- (1) the costs payable by the vendor under subclause 4.1(2) that the purchaser or the purchaser's conveyancer intends to deduct; and
 - (2) the amount of RLWT that the purchaser or the purchaser's conveyancer intends to withhold.

5.0 Risk and insurance

- 5.1 The property and chattels shall remain at the risk of the vendor until possession is given and taken.
- 5.2 If, prior to the giving and taking of possession, the property is destroyed or damaged, and such destruction or damage has not been made good by the settlement date, then the following provisions shall apply:
- (1) if the destruction or damage has been sufficient to render the property untenable and it is untenable on the settlement date, the purchaser may:
 - (a) complete the purchase at the purchase price, less a sum equal to any insurance moneys received or receivable by or on behalf of the vendor in respect of such destruction or damage, provided that no reduction shall be made to the purchase price if the vendor's insurance company has agreed to reinstate for the benefit of the purchaser to the extent of the vendor's insurance cover; or
 - (b) cancel this agreement by serving notice on the vendor in which case the vendor shall return to the purchaser immediately the deposit and any other moneys paid by the purchaser, and neither party shall have any right or claim against the other arising from this agreement or its cancellation;
 - (2) if the property is not untenable on the settlement date the purchaser shall complete the purchase at the purchase price less a sum equal to the amount of the diminution in value of the property which, to the extent that the destruction or damage to the property can be made good, shall be deemed to be equivalent to the reasonable cost of reinstatement or repair;
 - (3) in the case of a property zoned for rural purposes under an operative District Plan, damage to the property shall be deemed to have rendered the property untenable where the diminution in value exceeds an amount equal to 20% of the purchase price; and
 - (4) if the amount of the diminution in value is disputed, the parties shall follow the same procedure as that set out in subclause 8.4 for when an amount of compensation is disputed.
- 5.3 The purchaser shall not be required to take over any insurance policies held by the vendor.

6.0 Title, boundaries and requisitions

- 6.1 The vendor shall not be bound to point out the boundaries of the property except that on the sale of a vacant residential lot which is not limited as to parcels the vendor shall ensure that all boundary markers required by the Cadastral Survey Act 2002 and any related rules and regulations to identify the boundaries of the property are present in their correct positions at the settlement date.
- 6.2 (1) The purchaser is deemed to have accepted the vendor's title except as to objections or requisitions which the purchaser is entitled to make and notice of which the purchaser serves on the vendor on or before the earlier of:
- (a) the tenth working day after the date of this agreement; or
 - (b) the settlement date.
- (2) Where the transfer of the property is to be registered against a new title yet to be issued, the purchaser is deemed to have accepted the title except as to such objections or requisitions which the purchaser is entitled to make and notice of which the purchaser serves on the vendor on or before the fifth working day following the date the vendor has given the purchaser notice that the title has been issued and a search copy of it as defined in section 60 of the Land Transfer Act 2017 is obtainable.
- (3) If the vendor is unable or unwilling to remove or comply with any objection or requisition as to title, notice of which has been served on the vendor by the purchaser, then the following provisions will apply:
- (a) the vendor shall notify the purchaser ("a vendor's notice") of such inability or unwillingness on or before the fifth working day after the date of service of the purchaser's notice;
 - (b) if the vendor does not give a vendor's notice the vendor shall be deemed to have accepted the objection or requisition and it shall be a requirement of settlement that such objection or requisition shall be complied with before settlement;
 - (c) if the purchaser does not on or before the fifth working day after service of a vendor's notice notify the vendor that the purchaser waives the objection or requisition, either the vendor or the purchaser may (notwithstanding any intermediate negotiations) by notice to the other, cancel this agreement.
- (4) In the event of cancellation under subclause 6.2(3), the purchaser shall be entitled to the immediate return of the deposit and any other moneys paid under this agreement by the purchaser and neither party shall have any right or claim against the other arising from this agreement or its cancellation. In particular, the purchaser shall not be entitled to any interest or to the expense of investigating the title or to any compensation whatsoever.
- 6.3 (1) If the title to the property being sold is a cross lease title or a unit title and there are:
- (a) in the case of a cross lease title:
 - (i) alterations to the external dimensions of any leased structure; or
 - (ii) buildings or structures not intended for common use which are situated on any part of the land that is not subject to a restricted user covenant;
 - (b) in the case of a unit title, encroachments out of the principal unit or accessory unit title space (as the case may be);
- then the purchaser may requisition the title under subclause 6.2 requiring the vendor:
- (c) in the case of a cross lease title, to deposit a new plan depicting the buildings or structures and register a new cross lease or cross leases (as the case may be) and any other ancillary dealings in order to convey good title; or
 - (d) in the case of a unit title, to deposit an amendment to the unit plan, a redevelopment plan or new unit plan (as the case may be) depicting the principal and/or accessory units and register such transfers and any other ancillary dealings in order to convey good title.

- (2) The words "alterations to the external dimensions of any leased structure" shall only mean alterations which are attached to the leased structure and enclosed.
- 6.4 Except as provided by sections 36 to 42 of the Contract and Commercial Law Act 2017, no error, omission, or misdescription of the property or the title shall enable the purchaser to cancel this agreement but compensation, if claimed by notice before settlement in accordance with subclause 8.1 but not otherwise, shall be made or given as the case may require.
- 6.5 The vendor shall not be liable to pay for or contribute towards the expense of erection or maintenance of any fence between the property and any contiguous land of the vendor but this proviso shall not ensure for the benefit of any subsequent purchaser of the contiguous land; and the vendor shall be entitled to require the inclusion of a fencing covenant to this effect in any transfer of the property.

7.0 Vendor's warranties and undertakings

- 7.1 The vendor warrants and undertakes that at the date of this agreement the vendor has not:
- (1) received any notice or demand and has no knowledge of any requisition or outstanding requirement:
 - (a) from any local or government authority or other statutory body; or
 - (b) under the Resource Management Act 1991; or
 - (c) from any tenant of the property; or
 - (d) from any other party; or
 - (2) given any consent or waiver, which directly or indirectly affects the property and which has not been disclosed in writing to the purchaser.
- 7.2 The vendor warrants and undertakes that at settlement:
- (1) The chattels and all plant, equipment, systems or devices which provide any services or amenities to the property, including, without limitation, security, heating, cooling, or air-conditioning, are delivered to the purchaser in reasonable working order, but in all other respects in their state of repair as at the date of this agreement (fair wear and tear excepted) but failure so to deliver them shall only create a right of compensation.
 - (2) All electrical and other installations on the property are free of any charge whatsoever.
 - (3) There are no arrears of rates, water rates or charges outstanding on the property.
 - (4) Where an allowance has been made by the vendor in the settlement statement for incomings receivable, the settlement statement correctly records those allowances including, in particular, the dates up to which the allowances have been made.
 - (5) Where the vendor has done or caused or permitted to be done on the property any works:
 - (a) any permit, resource consent, or building consent required by law was obtained; and
 - (b) to the vendor's knowledge, the works were completed in compliance with those permits or consents; and
 - (c) where appropriate, a code compliance certificate was issued for those works.
 - (6) Where under the Building Act, any building on the property sold requires a compliance schedule:
 - (a) the vendor has fully complied with any requirements specified in any compliance schedule issued by a territorial authority under the Building Act in respect of the building;
 - (b) the building has a current building warrant of fitness; and
 - (c) the vendor is not aware of any reason, that the vendor has not disclosed in writing to the purchaser, which would prevent a building warrant of fitness from being supplied to the territorial authority when the building warrant of fitness is next due.
 - (7) Since the date of this agreement, the vendor has not given any consent or waiver which directly or indirectly affects the property.
 - (8) Any notice or demand received by the vendor, which directly or indirectly affects the property, after the date of this agreement:
 - (a) from any local or government authority or other statutory body; or
 - (b) under the Resource Management Act 1991; or
 - (c) from any tenant of the property; or
 - (d) from any other party,
 has been delivered forthwith by the vendor to either the purchaser or the purchaser's lawyer, unless the vendor has paid or complied with such notice or demand. If the vendor fails to so deliver or pay the notice or demand, the vendor shall be liable for any penalty incurred.
 - (9) Any chattels included in the sale are the unencumbered property of the vendor.
- 7.3 If the property is or includes part only of a building, the warranty and undertaking in subclause 7.2(6) does not apply. Instead the vendor warrants and undertakes at the date of this agreement that, where under the Building Act the building of which the property forms part requires a compliance schedule:
- (1) to the vendor's knowledge, there has been full compliance with any requirements specified in any compliance schedule issued by a territorial authority under the Building Act in respect of the building;
 - (2) the building has a current building warrant of fitness; and
 - (3) the vendor is not aware of any reason, that the vendor has not disclosed in writing to the purchaser, which would prevent a building warrant of fitness from being supplied to the territorial authority when the building warrant of fitness is next due.
- 7.4 The vendor warrants and undertakes that on or immediately after settlement:
- (1) If the water and wastewater charges are determined by meter, the vendor will have the water meter read and will pay the amount of the charge payable pursuant to that reading; but if the water supplier will not make special readings, the water and wastewater charges shall be apportioned.
 - (2) Any outgoings included in the settlement statement are paid in accordance with the settlement statement and, where applicable, to the dates shown in the settlement statement, or will be so paid immediately after settlement.
 - (3) The vendor will give notice of sale in accordance with the Local Government (Rating) Act 2002 to the territorial authority and regional council in whose district the land is situated and will also give notice of the sale to every other authority that makes and levies rates or charges on the land and to the supplier of water.
 - (4) Where the property is a unit title, the vendor will notify the body corporate in writing of the transfer of the property and the name and address of the purchaser.
- 7.5 If the purchaser has not validly cancelled this agreement, the breach of any warranty or undertaking contained in this agreement does not defer the obligation to settle but that obligation shall be subject to the rights of the purchaser at law or in equity, including any rights under subclause 6.4 and any right of equitable set-off.

8.0 Claims for compensation

- 8.1 If the purchaser claims a right to compensation either under subclause 6.4 or for an equitable set-off:
- (1) the purchaser must serve notice of the claim on the vendor on or before the last working day prior to settlement; and
 - (2) the notice must:
 - (a) in the case of a claim for compensation under subclause 6.4, state the particular error, omission, or misdescription of the property or title in respect of which compensation is claimed;
 - (b) in the case of a claim to an equitable set-off, state the particular matters in respect of which compensation is claimed;
 - (c) comprise a genuine pre-estimate of the loss suffered by the purchaser; and
 - (d) be particularised and quantified to the extent reasonably possible as at the date of the notice.
- 8.2 For the purposes of subclause 8.1(1), "settlement" means the date for settlement fixed by this agreement unless, by reason of the conduct or omission of the vendor, the purchaser is unable to give notice by that date, in which case notice may be given on or before the last working day prior to the date for settlement fixed by a valid settlement notice served by either party pursuant to subclause 11.1.
- 8.3 If the amount of compensation is agreed, it shall be deducted on settlement.
- 8.4 If the amount of compensation is disputed:
- (1) an interim amount shall be deducted on settlement and paid by the purchaser to a stakeholder until the amount of the compensation is determined;
 - (2) the interim amount must be a reasonable sum having regard to all of the circumstances;
 - (3) if the parties cannot agree on the interim amount, the interim amount shall be determined by an experienced property lawyer appointed by the parties. The appointee's costs shall be met equally by the parties. If the parties cannot agree on the appointee, the appointment shall be made on the application of either party by the president for the time being of the New Zealand Law Society;
 - (4) the stakeholder shall lodge the interim amount on interest-bearing call deposit with a bank registered under the Reserve Bank of New Zealand Act 1989 in the joint names of the vendor and the purchaser;
 - (5) the interest earned on the interim amount net of any withholding tax and any bank or legal administration fees and commission charges shall follow the destination of the interim amount;
 - (6) the amount of compensation determined to be payable shall not be limited by the interim amount; and
 - (7) if the parties cannot agree on a stakeholder, the interim amount shall be paid to a stakeholder nominated on the application of either party by the president for the time being of the New Zealand Law Society.
- 8.5 The procedures prescribed in subclauses 8.1 to 8.4 shall not prevent either party taking proceedings for the specific performance of the contract.

9.0 Unit title and cross lease provisions

Unit Titles

- 9.1 If the property is a unit title, sections 144 to 153 of the Unit Titles Act 2010 ("the Act") require the vendor to provide to the purchaser a pre-contract disclosure statement, a pre-settlement disclosure statement and, if so requested by the purchaser, an additional disclosure statement.
- 9.2 If the property is a unit title, the vendor warrants and undertakes as follows:
- (1) The information in the pre-contract disclosure statement provided to the purchaser was complete and correct.
 - (2) Apart from regular periodic contributions, no contributions have been levied or proposed by the body corporate that have not been disclosed in writing to the purchaser.
 - (3) Not less than five working days before the settlement date, the vendor will provide:
 - (a) a certificate of insurance for all insurances effected by the body corporate under the provisions of section 135 of the Act; and
 - (b) a pre-settlement disclosure statement from the vendor, certified correct by the body corporate, under section 147 of the Act. Any periodic contributions to the operating account shown in that pre-settlement disclosure statement shall be apportioned. There shall be no apportionment of contributions to any long-term maintenance fund, contingency fund or capital improvement fund.
 - (4) There are no other amounts owing by the owner under any provision of the Act or the Unit Titles Act 1972.
 - (5) There are no unsatisfied judgments against the body corporate and no proceedings have been instituted against or by the body corporate.
 - (6) No order or declaration has been made by any Court against the body corporate or the owner under any provision of the Act or the Unit Titles Act 1972.
 - (7) The vendor has no knowledge or notice of any fact which might give rise to or indicate the possibility of:
 - (a) the owner or the purchaser incurring any other liability under any provision of the Act or the Unit Titles Act 1972; or
 - (b) any proceedings being instituted by or against the body corporate; or
 - (c) any order or declaration being sought against the body corporate or the owner under any provision of the Act or the Unit Titles Act 1972.
 - (8) The vendor is not aware of proposals to pass any body corporate resolution relating to its rules nor are there any unregistered changes to the body corporate rules which have not been disclosed in writing to the purchaser.
 - (9) No lease, licence, easement, or special privilege has been granted by the body corporate in respect of any part of the common property which has not been disclosed in writing to the purchaser.
 - (10) No resolution has been passed and no application has been made and the vendor has no knowledge of any proposal for:
 - (a) the transfer of the whole or any part of the common property;
 - (b) the addition of any land to the common property;
 - (c) the cancellation of the unit plan; or
 - (d) the deposit of an amendment to the unit plan, a redevelopment plan, or a new unit plan in substitution for the existing unit plan,
 which has not been disclosed in writing to the purchaser.
 - (11) As at settlement, all contributions and other moneys payable by the vendor to the body corporate have been paid in full.
- 9.3 If the property is a unit title, in addition to the purchaser's rights under sections 149 and 150 of the Act, and if the vendor does not provide the certificates of insurance and the pre-settlement disclosure statement under section 147 in accordance with the requirements of subclause 9.2(3), the purchaser may:
- (1) postpone the settlement date until the fifth working day following the date on which that information is provided to the purchaser; or
 - (2) elect that settlement shall still take place on the settlement date.
- 9.4 If the property is a unit title, each party specifies that:
- (1) the facsimile number of the office of that party's lawyer shall be an address for service for that party for the purposes of section 205(1)(d) of the Act; and
 - (2) if that party is absent from New Zealand, that party's lawyer shall be that party's agent in New Zealand for the purposes of section 205(2) of the Act.
- 9.5 If the property is a unit title, any costs owing by the purchaser to the vendor pursuant to section 148(5) of the Act for providing an additional disclosure statement shall be included in the moneys payable by the purchaser on settlement pursuant to subclause 3.8(1). Such costs may be deducted from the deposit if the purchaser becomes entitled to a refund of the deposit upon cancellation or avoidance of this agreement.

Unauthorised Structures – Cross Leases and Unit Titles

- 9.6 (1) Where structures (not stated in clause 6.0 to be requisitionable) have been erected on the property without:
- (a) in the case of a cross lease title, any required lessors' consent; or
 - (b) in the case of a unit title, any required body corporate consent,
- the purchaser may demand within the period expiring on the earlier of:
- (i) the tenth working day after the date of this agreement; or
 - (ii) the settlement date,
- that the vendor obtain the written consent of the current lessors or the body corporate (as the case may be) to such improvements ("a current consent") and provide the purchaser with a copy of such consent on or before the settlement date.
- (2) Should the vendor be unwilling or unable to obtain a current consent then the procedure set out in subclauses 6.2(3) and 6.2(4) shall apply with the purchaser's demand under subclause 9.6(1) being deemed to be an objection and requisition.

10.0 Conditions and mortgage terms

Particular Conditions

- 10.1 If particulars of any finance condition(s) are inserted on the front page of this agreement, this agreement is conditional upon the purchaser arranging finance in terms of those particulars on or before the finance date.
- 10.2 (1) If the purchaser has indicated on the front page of this agreement that a LIM is required:
- (a) that LIM is to be obtained by the purchaser at the purchaser's cost;
 - (b) the purchaser is to request the LIM on or before the fifth working day after the date of this agreement; and
 - (c) this agreement is conditional upon the purchaser approving that LIM provided that such approval must not be unreasonably or arbitrarily withheld.
- (2) If, on reasonable grounds, the purchaser does not approve the LIM, the purchaser shall give notice to the vendor ("the purchaser's notice") on or before the fifteenth working day after the date of this agreement stating the particular matters in respect of which approval is withheld and, if those matters are capable of remedy, what the purchaser reasonably requires to be done to remedy those matters. If the purchaser does not give a purchaser's notice the purchaser shall be deemed to have approved the LIM. If through no fault of the purchaser, the LIM is not available on or before the fifteenth working day after the date of this agreement and the vendor does not give an extension when requested, this condition shall not have been fulfilled and the provisions of subclause 10.8(5) shall apply.
- (3) The vendor shall give notice to the purchaser ("the vendor's notice") on or before the fifth working day after receipt of the purchaser's notice advising whether or not the vendor is able and willing to comply with the purchaser's notice by the settlement date.
- (4) If the vendor does not give a vendor's notice, or if the vendor's notice advises that the vendor is unable or unwilling to comply with the purchaser's notice, and if the purchaser does not, on or before the tenth working day after the date on which the purchaser's notice is given, give notice to the vendor that the purchaser waives the objection to the LIM, this condition shall not have been fulfilled and the provisions of subclause 10.8(5) shall apply.
- (5) If the vendor gives a vendor's notice advising that the vendor is able and willing to comply with the purchaser's notice, this condition is deemed to have been fulfilled, and it shall be a requirement of settlement that the purchaser's notice shall be complied with, and also, if the vendor must carry out work on the property, that the vendor shall obtain the approval of the territorial authority to the work done, both before settlement.
- 10.3 If the purchaser has indicated on the front page of this agreement that a building report is required, this agreement is conditional upon the purchaser obtaining at the purchaser's cost on or before the tenth working day after the date of this agreement a report on the condition of the buildings and any other improvements on the property that is satisfactory to the purchaser, on the basis of an objective assessment. The report must be prepared in good faith by a suitably-qualified building inspector in accordance with accepted principles and methods. Subject to the rights of any tenants of the property, the vendor shall allow the building inspector to inspect the property at all reasonable times upon reasonable notice for the purposes of preparation of the report. The building inspector may not carry out any invasive testing in the course of inspection without the vendor's prior written consent. If the purchaser avoids this agreement for non-fulfilment of this condition pursuant to subclause 10.8(5), the purchaser must provide the vendor immediately upon request with a copy of the building inspector's report.
- 10.4 (1) If the purchaser has indicated on the front page of this agreement that OIA Consent is required, this agreement is conditional upon OIA Consent being obtained on or before the Land Act/OIA date shown on the front page of this agreement, the purchaser being responsible for payment of the application fee.
- (2) If the purchaser has indicated on the front page of this agreement that OIA Consent is not required, or has failed to indicate whether it is required, then the purchaser warrants that the purchaser does not require OIA Consent.
- 10.5 If this agreement relates to a transaction to which the Land Act 1948 applies, this agreement is subject to the vendor obtaining the necessary consent by the Land Act/OIA date shown on the front page of this agreement.
- 10.6 If the Land Act/OIA date is not shown on the front page of this agreement, that date shall be the settlement date or a date 95 working days from the date of this agreement whichever is the sooner, except where the property comprises residential (but not otherwise sensitive) land in which case that date shall be the settlement date or a date 20 working days from the date of this agreement whichever is the sooner.
- 10.7 If this agreement relates to a transaction to which section 225 of the Resource Management Act 1991 applies then this agreement is subject to the appropriate condition(s) imposed by that section.

Operation of Conditions

- 10.8 If this agreement is expressed to be subject either to the above or to any other condition(s), then in relation to each such condition the following shall apply unless otherwise expressly provided:
- (1) The condition shall be a condition subsequent.
 - (2) The party or parties for whose benefit the condition has been included shall do all things which may reasonably be necessary to enable the condition to be fulfilled by the date for fulfilment.
 - (3) Time for fulfilment of any condition and any extended time for fulfilment to a fixed date shall be of the essence.
 - (4) The condition shall be deemed to be not fulfilled until notice of fulfilment has been served by one party on the other party.
 - (5) If the condition is not fulfilled by the date for fulfilment, either party may at any time before the condition is fulfilled or waived avoid this agreement by giving notice to the other. Upon avoidance of this agreement, the purchaser shall be entitled to the immediate return of the deposit and any other moneys paid by the purchaser under this agreement and neither party shall have any right or claim against the other arising from this agreement or its termination.
 - (6) At any time before this agreement is avoided, the purchaser may waive any finance condition and either party may waive any other condition which is for the sole benefit of that party. Any waiver shall be by notice.

Mortgage Terms

- 10.9 Any mortgage to be arranged pursuant to a finance condition shall be upon and subject to the terms and conditions currently being required by the lender in respect of loans of a similar nature.
- 10.10 If the vendor is to advance mortgage moneys to the purchaser then, unless otherwise stated, the mortgage shall be in the appropriate "fixed sum" form currently being published by Auckland District Law Society Incorporated.

11.0 Notice to complete and remedies on default

- 11.1 (1) If the sale is not settled on the settlement date, either party may at any time thereafter serve on the other party a settlement notice.
 (2) The settlement notice shall be effective only if the party serving it is at the time of service either in all material respects ready, able, and willing to proceed to settle in accordance with this agreement or is not so ready, able, and willing to settle only by reason of the default or omission of the other party.
 (3) If the purchaser is in possession, the vendor's right to cancel this agreement will be subject to sections 28 to 36 of the Property Law Act 2007 and the settlement notice may incorporate or be given with a notice under section 28 of that Act complying with section 29 of that Act.
- 11.2 Subject to subclause 11.1(3), upon service of the settlement notice the party on whom the notice is served shall settle:
- (1) on or before the twelfth working day after the date of service of the notice; or
 - (2) on the first working day after the 13th day of January if the period of twelve working days expires during the period commencing on the 6th day of January and ending on the 13th day of January, both days inclusive,
- time being of the essence, but without prejudice to any intermediate right of cancellation by either party.
- 11.3 (1) If this agreement provides for the payment of the purchase price by instalments and the purchaser fails duly and punctually to pay any instalment on or within one month from the date on which it fell due for payment then, whether or not the purchaser is in possession, the vendor may immediately give notice to the purchaser calling up the unpaid balance of the purchase price, which shall upon service of the notice fall immediately due and payable.
 (2) The date of service of the notice under this subclause shall be deemed the settlement date for the purposes of subclause 11.1.
 (3) The vendor may give a settlement notice with a notice under this subclause.
 (4) For the purpose of this subclause a deposit is not an instalment.
- 11.4 If the purchaser does not comply with the terms of the settlement notice served by the vendor then, subject to subclause 11.1(3):
- (1) Without prejudice to any other rights or remedies available to the vendor at law or in equity, the vendor may:
 - (a) sue the purchaser for specific performance; or
 - (b) cancel this agreement by notice and pursue either or both of the following remedies namely:
 - (i) forfeit and retain for the vendor's own benefit the deposit paid by the purchaser, but not exceeding in all 10% of the purchase price; and/or
 - (ii) sue the purchaser for damages.
 - (2) Where the vendor is entitled to cancel this agreement, the entry by the vendor into a conditional or unconditional agreement for the resale of the property or any part thereof shall take effect as a cancellation of this agreement by the vendor if this agreement has not previously been cancelled and such resale shall be deemed to have occurred after cancellation.
 - (3) The damages claimable by the vendor under subclause 11.4(1)(b)(ii) shall include all damages claimable at common law or in equity and shall also include (but shall not be limited to) any loss incurred by the vendor on any bona fide resale contracted within one year from the date by which the purchaser should have settled in compliance with the settlement notice. The amount of that loss may include:
 - (a) interest on the unpaid portion of the purchase price at the interest rate for late settlement from the settlement date to the settlement of such resale; and
 - (b) all costs and expenses reasonably incurred in any resale or attempted resale; and
 - (c) all outgoings (other than interest) on or maintenance expenses in respect of the property from the settlement date to the settlement of such resale.
 - (4) Any surplus money arising from a resale as aforesaid shall be retained by the vendor.
- 11.5 If the vendor does not comply with the terms of a settlement notice served by the purchaser, then, without prejudice to any other rights or remedies available to the purchaser at law or in equity the purchaser may:
- (1) sue the vendor for specific performance; or
 - (2) cancel this agreement by notice and require the vendor forthwith to repay to the purchaser any deposit and any other money paid on account of the purchase price and interest on such sum(s) at the interest rate for late settlement from the date or dates of payment by the purchaser until repayment.
- 11.6 The party serving a settlement notice may extend the term of the notice for one or more specifically stated periods of time and thereupon the term of the settlement notice shall be deemed to expire on the last day of the extended period or periods and it shall operate as though this clause stipulated the extended period(s) of notice in lieu of the period otherwise applicable; and time shall be of the essence accordingly. An extension may be given either before or after the expiry of the period of the notice.
- 11.7 Nothing in this clause shall preclude a party from suing for specific performance without giving a settlement notice.
- 11.8 A party who serves a settlement notice under this clause shall not be in breach of an essential term by reason only of that party's failure to be ready and able to settle upon the expiry of that notice.

12.0 Non-merger

- 12.1 The obligations and warranties of the parties in this agreement shall not merge with:
- (1) the giving and taking of possession;
 - (2) settlement;
 - (3) the transfer of title to the property;
 - (4) delivery of the chattels (if any); or
 - (5) registration of the transfer of title to the property.

13.0 Agent

- 13.1 If the name of a licensed real estate agent is recorded on this agreement, it is acknowledged that the sale evidenced by this agreement has been made through that agent whom the vendor appoints as the vendor's agent to effect the sale. The vendor shall pay the agent's charges including GST for effecting such sale.
- 13.2 The agent may provide statistical data relating to the sale to the Real Estate Institute of New Zealand Incorporated.

14.0 Goods and Services Tax

- 14.1 If this agreement provides for the purchaser to pay (in addition to the purchase price stated without GST) any GST which is payable in respect of the supply made under this agreement then:
- (1) the purchaser shall pay to the vendor the GST which is so payable in one sum on the GST date;
 - (2) where the GST date has not been inserted on the front page of this agreement the GST date shall be the settlement date;
 - (3) where any GST is not so paid to the vendor, the purchaser shall pay to the vendor:
 - (a) interest at the interest rate for late settlement on the amount of GST unpaid from the GST date until payment; and
 - (b) any default GST;
 - (4) it shall not be a defence to a claim against the purchaser for payment to the vendor of any default GST that the vendor has failed to mitigate the vendor's damages by paying an amount of GST when it fell due under the GST Act; and
 - (5) any sum referred to in this clause is included in the moneys payable by the purchaser on settlement pursuant to subclause 3.8(1).
- 14.2 If the supply under this agreement is a taxable supply, the vendor will deliver a tax invoice to the purchaser on or before the GST date or such earlier date as the purchaser is entitled to delivery of an invoice under the GST Act.
- 14.3 The vendor warrants that any dwelling and curtilage or part thereof supplied on sale of the property are not a supply to which section 5(16) of the GST Act applies.

- 14.4 (1) Without prejudice to the vendor's rights and remedies under subclause 14.1, where any GST is not paid to the vendor on or within one month of the GST date, then whether or not the purchaser is in possession, the vendor may immediately give notice to the purchaser calling up any unpaid balance of the purchase price, which shall upon service of the notice fall immediately due and payable.
- (2) The date of service of the notice under this subclause shall be deemed the settlement date for the purposes of subclause 11.1.
- (3) The vendor may give a settlement notice under subclause 11.1 with a notice under this subclause.

15.0 Zero-rating

- 15.1 The vendor warrants that the statement on the front page regarding the vendor's GST registration status in respect of the supply under this agreement is correct at the date of this agreement.
- 15.2 The purchaser warrants that any particulars stated by the purchaser in Schedule 1 are correct at the date of this agreement.
- 15.3 Where the particulars stated on the front page and in Schedule 1 indicate that:
- (1) the vendor is and/or will be at settlement a registered person in respect of the supply under this agreement;
 - (2) the recipient is and/or will be at settlement a registered person;
 - (3) the recipient intends at settlement to use the property for making taxable supplies; and
 - (4) the recipient does not intend at settlement to use the property as a principal place of residence by the recipient or a person associated with the recipient under section 2A(1)(c) of the GST Act,
- GST will be chargeable on the supply under this agreement at 0% pursuant to section 11(1)(mb) of the GST Act.
- 15.4 If GST is chargeable on the supply under this agreement at 0% pursuant to section 11(1)(mb) of the GST Act, then on or before settlement the purchaser will provide the vendor with the recipient's name, address, and registration number if any of those details are not included in Schedule 1 or they have altered.
- 15.5 If any of the particulars stated by the purchaser in Schedule 1 should alter between the date of this agreement and settlement, the purchaser shall notify the vendor of the altered particulars and of any other relevant particulars in Schedule 1 which may not have been completed by the purchaser as soon as practicable and in any event no later than two working days before settlement. The purchaser warrants that any altered or added particulars will be correct as at the date of the purchaser's notification. If the GST treatment of the supply under this agreement should be altered as a result of the altered or added particulars, the vendor shall prepare and deliver to the purchaser or the purchaser's lawyer an amended settlement statement if the vendor has already tendered a settlement statement, and a credit note or a debit note, as the case may be, if the vendor has already issued a tax invoice.
- 15.6 If
- (1) the particulars in Schedule 1 state that part of the property is being used as a principal place of residence at the date of this agreement; and
 - (2) that part is still being so used at the time of the supply under this agreement,
- the supply of that part will be a separate supply in accordance with section 5(15)(a) of the GST Act.
- 15.7 If
- (1) the particulars stated in Schedule 1 indicate that the recipient intends to use part of the property as a principal place of residence by the recipient or a person associated with the recipient under section 2A(1)(c) of the GST Act; and
 - (2) that part is the same part as that being used as a principal place of residence at the time of the supply under this agreement,
- then the references in subclauses 15.3 and 15.4 to "the property" shall be deemed to mean the remainder of the property excluding that part and the references to "the supply under this agreement" shall be deemed to mean the supply under this agreement of that remainder.

16.0 Supply of a Going Concern

- 16.1 If there is a supply under this agreement to which section 11(1)(mb) of the GST Act does not apply but which comprises the supply of a taxable activity that is a going concern at the time of the supply, then, unless otherwise expressly stated herein:
- (1) each party warrants that it is a registered person or will be so by the date of the supply;
 - (2) each party agrees to provide the other party by the date of the supply with proof of its registration for GST purposes;
 - (3) the parties agree that they intend that the supply is of a taxable activity that is capable of being carried on as a going concern by the purchaser; and
 - (4) the parties agree that the supply made pursuant to this agreement is the supply of a going concern on which GST is chargeable at 0%.
- 16.2 If it subsequently transpires that GST is payable in respect of the supply and if this agreement provides for the purchaser to pay (in addition to the purchase price without GST) any GST which is payable in respect of the supply made under this agreement, then the provisions of clause 14.0 of this agreement shall apply.

17.0 Limitation of Liability

- 17.1 If any person enters into this agreement as trustee of a trust, then:
- (1) That person warrants that:
 - (a) the person has power to enter into this agreement under the terms of the trust;
 - (b) the person has properly signed this agreement in accordance with the terms of the trust;
 - (c) the person has the right to be indemnified from the assets of the trust and that right has not been lost or impaired by any action of that person including entry into this agreement; and
 - (d) all of the persons who are trustees of the trust have approved entry into this agreement.
 - (2) If that person has no right to or interest in any assets of the trust except in that person's capacity as a trustee of the trust, that person's liability under this agreement will not be personal and unlimited but will be limited to the actual amount recoverable from the assets of the trust from time to time ("the limited amount"). If the right of that person to be indemnified from the trust assets has been lost or impaired, that person's liability will become personal but limited to the extent of that part of the limited amount which cannot be recovered from any other person.

18.0 Counterparts

- 18.1 This agreement may be executed in two or more counterparts, all of which will together be deemed to constitute one and the same agreement. A party may enter into this agreement by signing a counterpart copy and sending it to the other party, including by facsimile or e-mail.

FURTHER TERMS OF SALE

Further Terms continued on Appendix page



SCHEDULE 1**(GST Information – see clause 15.0)**

This Schedule must be completed if the vendor has stated on the front page that the vendor is registered under the GST Act in respect of the transaction evidenced by this agreement and/or will be so registered at settlement. Otherwise there is no need to complete it.

Section 1

1.	The vendor's registration number (if already registered):	
2.	Part of the property is being used as a principal place of residence at the date of this agreement. That part is: (e.g. "the main farmhouse" or "the apartment above the shop")	Yes/No
3.	The purchaser is registered under the GST Act and/or will be so registered at settlement.	Yes/No
4.	The purchaser intends at settlement to use the property for making taxable supplies.	Yes/No

If the answer to either or both of questions 3 and 4 is "No", go to question 7

5.	The purchaser's details are as follows: (a) Full name:	
	(b) Address:	
	(c) Registration number (if already registered):	
6.	The purchaser intends at settlement to use the property as a principal place of residence by the purchaser or by a person associated with the purchaser under section 2A(1)(c) of the GST Act (connected by blood relationship, marriage, civil union, de facto relationship or adoption). OR The purchaser intends at settlement to use part of the property (and no other part) as a principal place of residence by the purchaser or by a person associated with the purchaser under section 2A(1)(c) of the GST Act. That part is: (e.g. "the main farmhouse" or "the apartment above the shop")	Yes/No Yes/No
7.	The purchaser intends to direct the vendor to transfer title to the property to another party ("nominee").	Yes/No

If the answer to question 7 is "Yes", then please continue. Otherwise, there is no need to complete this Schedule any further.

Section 2

8.	The nominee is registered under the GST Act and/or is expected by the purchaser to be so registered at settlement.	Yes/No
9.	The purchaser expects the nominee at settlement to use the property for making taxable supplies.	Yes/No

If the answer to either or both of questions 8 and 9 is "No", there is no need to complete this Schedule any further.

10.	The nominee's details (if known to the purchaser) are as follows: (a) Full name:	
	(b) Address:	
	(c) Registration number (if already registered):	
11.	The purchaser expects the nominee to intend at settlement to use the property as a principal place of residence by the nominee or by a person associated with the nominee under section 2A(1)(c) of the GST Act (connected by blood relationship, marriage, civil union, de facto relationship or adoption). OR The purchaser expects the nominee to intend at settlement to use part of the property (and no other part) as a principal place of residence by the nominee or by a person associated with the nominee under section 2A(1)(c) of the GST Act. That part is: (e.g. "the main farmhouse" or "the apartment above the shop").	Yes/No Yes/No

SCHEDULE 2

List all chattels included in the sale

*(strike out or add as applicable)***Stove****Fixed floor coverings****Blinds****Curtains****Light fittings**

Garage door remotes x 2, ceiling fans x 3, clothesline x 2, dishwasher x 2, ~~baby bars x 2~~, heated towel rails x 2, hob induction x 2, rangehood x 2, ovens x 2, washing machine taps, waste disposal x 2, wood burner, solar panels x 16, 25,000 litre water tanks x 2, water bore

WARNING *(This warning does not form part of this agreement)*

This is a binding contract. **Read the information set out on the back page before signing.**

Acknowledgements

Where this agreement relates to the sale of a residential property and this agreement was provided to the parties by a real estate agent, or by a licensee on behalf of the agent, the parties acknowledge that they have been given the guide about the sale of residential property approved by the Real Estate Agents Authority.

Where this agreement relates to the sale of a unit title property, the purchaser acknowledges that the purchaser has been provided with a pre-contract disclosure statement under section 146 of the Unit Titles Act 2010.

Signature of Purchaser(s):

Signature of Vendor(s):

Director / Trustee / Authorised Signatory / Attorney**Delete the options that do not apply**If no option is deleted, the signatory is signing in their personal capacity*_____
Director / Trustee / Authorised Signatory / Attorney**Delete the options that do not apply**If no option is deleted, the signatory is signing in their personal capacity*_____
Director / Trustee / Authorised Signatory / Attorney**Delete the options that do not apply**If no option is deleted, the signatory is signing in their personal capacity*_____
Director / Trustee / Authorised Signatory / Attorney**Delete the options that do not apply**If no option is deleted, the signatory is signing in their personal capacity*

*If this agreement is signed under:

- (i) a Power of Attorney – please attach a **Certificate of non-revocation** (available from ADLS: 4098WFP or REINZ); or
- (ii) an Enduring Power of Attorney – please attach a **Certificate of non-revocation and non-suspension of the enduring power of attorney** (available from ADLS: 4997WFP or REINZ).

Also insert the following wording for the Attorney's Signature above:

Signed by [full name of the donor] by his or her Attorney [attorney's signature].

Appendix

19.0 Registered Interest

Where a title has been supplied or shown to the Customers, the Purchasers acknowledge they have been advised that any interest noted on the search copy of the title to the property whether by way of covenant, easement, caveat or memorial or otherwise should be referred to a lawyer or an expert trained in law and experienced in property law, for independent advice, prior to purchasing the property.

This advice is in addition to and does not take precedence over the Purchaser's rights under standard Clause 6.0 or any other clause in the contract.

20.0 Vendor and Purchaser Acknowledgements

20.1 Legal, Technical and Other Advice:

The vendor and the purchaser both acknowledge that before signing this agreement they have had a reasonable opportunity to seek legal, technical and other advice or information and that they have either obtained that advice or information; or have included a provision in this Agreement to obtain that advice or information; or have decided not to do so of their own accord.

20.2 Should the Purchaser have decided not to obtain their own specialist advice, they are deemed to have satisfied themselves on all aspects of the property and are buying solely in reliance on their own judgement, and contrary to the agent's recommendations.

20.3 Any offer accepted is on the basis of the purchaser acknowledging that they have received the agent's recommendation to obtain specialist independent advice as stated above.

20.4 Approval Guide for Sale and Purchase Agreement:

The vendor and purchaser both acknowledge that before signing this Agreement they have been given a copy of the approved New Zealand Residential Property Sale and Purchase Agreements guide relating to sale and purchase agreements published by the Real Estate Agents Authority.

20.5 Complaints and Dispute Resolution:

The vendor and purchaser both acknowledge that before signing this agreement they have been made aware of the Agent's in-house complaints and dispute resolution procedures. The vendor and purchaser have also been advised that they may access the Real Estate Agents Authority's complaints process and additional information at www.reea.govt.nz without first using the in-house procedures and that any use of the in-house procedures does not preclude them making a complaint to the Authority.

21.0 Water Tightness

The customers acknowledge upon the signing of this agreement that the Bayleys Real Estate Ltd representative:

- (i) has not made any representations as to the water tightness and structural integrity of the building or buildings situated on this property and
- (ii) has advised the customers to seek independent advice from a specialist on the water tightness and structural integrity of the building or buildings on this property.

Signature of the Vendor(s)

.....

Signature of the Purchaser(s)

.....

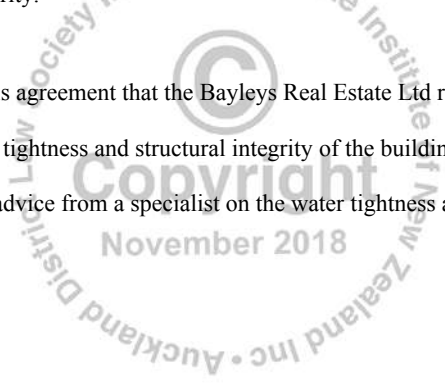

BEFORE SIGNING THE AGREEMENT

- It is recommended both parties seek professional advice before signing. This is especially so if:
 - there are any doubts. Once signed, this will be a binding contract with only restricted rights of termination.
 - the purchaser is not a New Zealand citizen. There are strict controls on the purchase of property in New Zealand by persons who are not New Zealand citizens.
 - property such as a hotel or a farm is being sold. The agreement is designed primarily for the sale of residential and commercial property.
 - the property is vacant land in the process of being subdivided or there is a new unit title or cross lease to be issued. In these cases additional clauses may need to be inserted.
 - there is any doubt as to the position of the boundaries.
 - the purchaser wishes to check the weathertightness and soundness of construction of any dwellings or other buildings on the land.
- Both parties may need to have customer due diligence performed on them by their lawyer or conveyancer in accordance with the Anti-Money Laundering and Countering Financing of Terrorism Act 2009 which is best done prior to the signing of this agreement.
- The purchaser should investigate the status of the property under the Council's District Plan. The property and those around it are affected by zoning and other planning provisions regulating their use and future development.
- The purchaser should investigate whether necessary permits, consents and code compliance certificates have been obtained from the Council where building works have been carried out. This investigation can be assisted by obtaining a LIM from the Council.
- The purchaser should compare the title plans against the physical location of existing structures where the property is a unit title or cross lease. Structures or alterations to structures not shown on the plans may result in the title being defective.
- In the case of a unit title, before the purchaser enters into the agreement:
 - the vendor **must** provide to the purchaser a pre-contract disclosure statement under section 146 of the Unit Titles Act 2010;
 - the purchaser should check the minutes of the past meetings of the body corporate, enquire whether there are any issues affecting the units and/or the common property, check the body corporate's long term maintenance plan and enquire whether the body corporate has imposed or proposed levies for a long term maintenance fund or any other fund for the maintenance of, or remedial or other work to, the common property.
- The vendor should ensure the warranties and undertakings in clauses 7.0 and 9.0:
 - are able to be complied with; and if not
 - the applicable warranty is deleted from the agreement and any appropriate disclosure is made to the purchaser.
- Both parties should ensure the chattels list in Schedule 2 is accurate.
- Before signing this agreement, both parties should seek professional advice regarding the GST treatment of the transaction. This depends upon the GST information supplied by the parties and could change before settlement if that information changes.

THE ABOVE NOTES ARE NOT PART OF THIS AGREEMENT AND ARE NOT A COMPLETE LIST OF MATTERS WHICH ARE IMPORTANT IN CONSIDERING THE LEGAL CONSEQUENCES OF THIS AGREEMENT.

PROFESSIONAL ADVICE SHOULD BE SOUGHT REGARDING THE EFFECT AND CONSEQUENCES OF ANY AGREEMENT ENTERED INTO BETWEEN THE PARTIES.

THE PURCHASER IS ENTITLED TO A COPY OF ANY SIGNED OFFER AT THE TIME IT IS MADE.

© Auckland District Law Society Inc. (ADLS) & Real Estate Institute of New Zealand Inc. (REINZ)

IMPORTANT: All copyright in and associated with this form is owned by ADLS & REINZ. The purchaser only acquires a limited non-exclusive licence to use this form *once within a single transaction only*. The standard ADLS or REINZ contract terms apply which also prohibit any form of reproduction, including copying, digitising or recreating the form by any means whatsoever.

WARNING: ADLS & REINZ monitor the use of its forms and may take enforcement action against any person acting in breach of these obligations.

These forms cannot be distributed or on sold to another party by the purchaser unless the written agreement of ADLS or REINZ has been obtained.

AGREEMENT FOR SALE AND PURCHASE OF REAL ESTATE

© The copyright to the form is owned by the Real Estate Institute of New Zealand Incorporated and Auckland District Law Society Incorporated.

DATE:

VENDOR:

Russell Mark Constant and Rozlyn Ann Constant

Contact Details:

3 Karaka Road RD 5

Papakura

Auckland

2585

VENDOR'S LAWYERS:

Firm: Galbraiths

Individual Acting: Irene Dawson

Contact Details:

P O Box 38345

Howick

Auckland

2145

Ph: 09 535 4190

Fax: 09 535 4191

Email: irene@galbraiths.co.nz

PURCHASER:

Contact Details:

PURCHASER'S LAWYERS:

Firm:

Individual Acting:

Contact Details:

LICENSED REAL ESTATE AGENT:

Bayleys Real Estate Limited - Manukau Residential

Agent's Name: a Member of the Bayleys Realty Group

Manager: Alan Owens

Salesperson: Clare Nicholson

(021 290 0505)

Contact Details:

2 Harris Road

East Tamaki

AUCKLAND 2013

alan.owens@bayleys.co.nz

Ph: 09 534 5189

Fax: 09 534 2382



Can you buy a home in New Zealand to live in?

Most overseas people are not able to buy homes in New Zealand to live in, but some can apply to the Overseas Investment Office for consent.

You don't need consent if...



- You are a New Zealand, Australian or Singaporean citizen.
- You have a New Zealand, Australian or Singaporean Permanent Resident visa and live in New Zealand.*
- You have a New Zealand Resident visa and live in New Zealand.*

*You have lived in New Zealand for at least 183 days in the past 12 months.

You must apply for consent to buy one home to live in if...



- You have a New Zealand Permanent Resident or Resident visa and do not live in New Zealand.*
- You have an Australian or Singaporean Permanent Resident visa and do not live in New Zealand.*

*To get consent you'll need to live in New Zealand, and if you stop living here, you'll have to sell.

You can't buy one home to live in if...



- You have a Temporary visa, such as a visitor, student, working holiday, or work visa (you don't have a Permanent Resident or Resident visa).

There are other ways you may be able to invest in property.

Check if you can buy

Visit the Ministry of Business, Innovation & Employment website at <https://www.newzealandnow.govt.nz/overseas>



What types of homes are affected?

These laws apply to homes that are classed as 'residential' or 'lifestyle' on the District Valuation Roll. You can check properties on websites, such as www.qv.co.nz, or ask the local council.

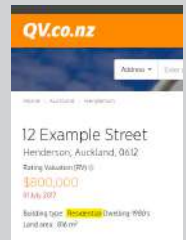

Everyone must make a 'Statement'

All buyers must complete a Residential Land Statement to say whether they are eligible to buy. Your conveyancer can help you do this.

If you must apply or cannot buy, it is especially important that you first talk to your conveyancer before you sign the sale and purchase agreement. If you need to sign it urgently, you can make the agreement conditional on the consent of the Overseas Investment Office.

If you need consent, but sign an unconditional agreement without it, you may face significant penalties. If you make a false statement, you could be fined up to \$300,000.

Apply for consent

To apply to the Overseas Investment Office for consent to buy one home to live in visit www.linz.govt.nz/oio/live.

Learn more

This leaflet gives general guidance for people who want to buy a home to live in. There are special rules for overseas people who want to invest in New Zealand property, but not live in it, including buying rental property or land that is rural or next to a lake, river, reserve or the sea.

These rules are complex, and you will need the help of a New Zealand property lawyer. Visit the Overseas Investment Office at www.linz.govt.nz/oio to learn more.



Residential Land Statement

Section 51A of the Overseas Investment Act 2005

A separate Residential Land Statement will need to be completed for each individual or entity (non-individual/corporate).
Individuals complete Part 1a, entities (non-individual/corporate) complete Part 1b.

Part 1a Individuals

I am an individual completing the statement for myself (*purchasing the residential land in your own name*)

Am I eligible to buy under the Overseas Investment Act 2005?

(Tick which applies)

Yes, I am a current New Zealand citizen

Yes, I am an Australian or Singaporean citizen buying residential land only

Yes, I hold a New Zealand residence class visa **or** Australian or Singaporean Permanent Resident visa **and all** of the following applies:

- I have been residing in New Zealand for at least the immediately preceding 12 months; and
- I am a tax resident in New Zealand; and
- I have been present in New Zealand for 183 days or more in the immediately preceding 12 months.

Yes, I am an Australian or Singaporean Citizen buying residential land that is also sensitive for another reason and I have consent from the Overseas Investment Office

→ Please provide Overseas Investment Office case number

Yes, I have consent from the Overseas Investment Office

→ Please provide Overseas Investment Office case number

Yes, an exemption applies

→ Please provide Overseas Investment Office case number or statutory reference

If you require consent and have not applied, or an exemption does not apply, contact the Overseas Investment Office or seek legal advice.

Part 1b Entities (non-individual/corporate)

(Tick which applies)

I am completing the statement for a body corporate, company, partnership or other entity

I am completing the statement for someone else under an enduring power of attorney or on behalf of trustees of a trust

→  Please attach a certificate of non-revocation if you are acting under an enduring power of attorney

Is the entity eligible to buy under the Overseas Investment Act 2005?

Yes, the entity is neither an overseas person nor an associate of an overseas person

Yes, the entity has consent from the Overseas Investment Office

→ Please provide Overseas Investment Office case number

Part 2

Name(s) of person or entity

What is the full name(s) of the person or entity that will appear on the record of title as the new owner(s)?

Part 3

The residential land being acquired

What is the record of title reference for the residential land or the street address?

Part 4

Signature

I certify that all of the information in this statement is true and correct.

Your name

Signature

Date signed

Position or office held (if signing as an authorised person)



You must provide this statement to your conveyancer or lawyer

Conveyancers will rely on the information provided in the statement in giving effect to the acquisition of the interest in residential land.

Providing a statement that is false or misleading is an offence under the Overseas Investment Act 2005 and you may be liable for a penalty of up to \$300,000.

Contact the Overseas Investment Office

Phone: 0800 665 463 (in NZ) or +64 7 974 5595 (if overseas)

Email address: oio@linz.govt.nz

Website address: www.linz.govt.nz/oio

Important things to know:

1. A sale and purchase agreement is a **legally binding** contract.
2. The real estate agent is **working for the seller** of the property, but must treat the buyer fairly.
3. You need to understand the difference between a **conditional** and an **unconditional** agreement.
4. You can **negotiate** the conditions you require in a sale and purchase agreement.
5. Make sure you **read** and **understand** the sale and purchase agreement before signing it.
6. It is recommended that you get your **lawyer to check** the sale and purchase agreement before you sign it.

Introduction

Buying or selling a home is one of the biggest financial commitments you will ever make. There are several relatively complicated stages to negotiate and there are a number of things to look out for.

When you are buying or selling residential property you should always have a written sale and purchase agreement. This is the legal document that forms the contract between the buyer and the seller.

This is a guide to the sale and purchase agreement that you will be asked to sign if you wish to buy or sell residential property.

This guide provides information about sale and purchase agreements, tells you where you can get more information, what to expect from a real estate agent¹ and what to do if there is a problem.

This guide only relates to the sale of residential property.

This guide is just that – guidance. You should not rely on it for legal advice. It's been prepared by the Real Estate Agents Authority (REAA), a Crown entity established by the Real Estate Agents Act 2008.

Whether you are a buyer or a seller, the agent must provide you with a copy of this guide before you sign a sale and purchase agreement, and ask you for written acknowledgement that you have received it. If you require more information, you can consult your lawyer. Information is also available on the REAA's website: www.reaa.govt.nz.

Why do I need a sale and purchase agreement?

A sale and purchase agreement provides certainty to both the buyer and the seller as it sets out in writing all the agreed terms and conditions. It is a legally binding contract.

Can I negotiate?

The seller and buyer can negotiate, through the agent, on price and conditions until they both reach agreement.

Important things to know:

- You should have a written sale and purchase agreement.
- Always read the sale and purchase agreement before signing it.
- Have your lawyer check the sale and purchase agreement before you sign it.
- Both the buyer and seller can negotiate changes to the price and conditions.
- A sale and purchase agreement is a legally binding contract.

The sale and purchase agreement

Your agent will probably use the Auckland District Law Society and Real Estate Institute of New Zealand form (the ADLS form).

Your sale and purchase agreement should include the following:

- The name(s) of the seller(s) and buyer(s).
- The address of the property.
- The type of title (freehold, leasehold etc.).
- The chattels that are to be sold with the property (e.g. whiteware, drapes, television aerial etc.).
- The price.

- The rate of interest that the buyer must pay on any overdue payments.
- Any deposit that the buyer must pay.
- Any conditions the buyer wants fulfilled before the contract is agreed.
- The date on which the agreement will become unconditional if there are conditions.
- The settlement date (the date the buyer pays the remainder of the amount for the property, usually the day when the buyer can move into the property).

Conditions in the document

The buyer will usually want to have some or all of the following conditions fulfilled before the contract is agreed:

- **Title search** – this is done by the buyer's lawyer to check who the legal owner of the property is and to see if anyone else has any claim over the property.
- **Finance** – this refers to the buyer arranging payment, normally a loan, by a specified date.
- **Valuation report** – normally required by a lender, this report is an estimate of the property's worth on the current market.
- **Land Information Memorandum (LIM) report** – provided by the local council, this report provides information on things such as rates, building permits and consents, drainage and planning.
- **Building inspection report** – these help determine how sound the building is and what might need to be repaired.
- **Engineer's report** – similar to the above but more focused on the section and structure of the property.
- **Sale of another home** – the buyer may need to sell their home in order to buy another.

General or standard clauses

A sale and purchase agreement also includes clauses that set out general obligations and conditions. It helps to understand what these mean as you will need to comply with them. Examples may include:

- **Access rights** – what access the buyer can have to inspect the property before settlement.
- **Default by buyer** – the buyer may have to compensate the seller e.g. interest payments.
- **Default by the seller** – the seller may have to compensate the buyer e.g. accommodation costs.
- **Insurance** – makes sure the property remains insured until the settlement date and outlining what will happen if any damage does occur.

Your lawyer will explain these clauses.

When does the buyer pay the deposit and the full amount?

When the seller and buyer have agreed on all aspects of the sale and purchase agreement, any deposit is usually paid to the real estate agent by the buyer. This money is initially held in the agent's trust account.

The agent usually takes their commission from the deposit when the contract becomes unconditional. This is agreed between the seller and the agent as set out in the agency agreement². The seller should make sure that the deposit is large enough to cover the agent's commission.

The buyer pays the remainder of the amount for the property on the day of settlement, usually through their lawyer. The settlement day is usually the date when the buyer can move into the property.

Before the sale and purchase agreement becomes unconditional and if the sale doesn't go ahead because some of the conditions haven't been met, the buyer may be entitled to have the deposit refunded in full.

However, once the offer becomes unconditional you won't be able to get your deposit back if you change your mind for any reason.

What is the difference between a conditional and an unconditional agreement?

- **Conditional** refers to the sale and purchase agreement having a set of conditions that are to be met, such as the buyer's current house being sold, a building inspection being carried out, or finance being secured.
- **Unconditional** refers to when all conditions in the sale and purchase agreement have been met and the transaction is ready to proceed to a change of ownership.

¹ Real estate agent or agent are general terms that refer to an agent, branch manager or salesperson.

² Refer to the Real Estate Agents Authority's New Zealand Residential Property Agency Agreement Guide

Can I cancel the agreement if I change my mind?

You cannot cancel a sale and purchase agreement just because you have had second thoughts about buying or selling the property concerned.

In general, once you have signed a sale and purchase agreement and the conditions set out in it have been met, you will have to go ahead with the sale/purchase of the property.

What can I expect from an agent?

The agent works for and is paid by the seller. The agent must therefore carry out the seller's instructions (as set out in the agency agreement) and act in the interests of the seller.

Agents also have clear responsibilities to buyers even though they are representing the seller.

When you are buying a property, ask the agent questions. Be specific about what you want to know.

All agents are bound by the Code of Professional Conduct and Client Care, issued by the REAA. Under the Code, agents have to deal fairly and honestly with all parties.

A copy of the Code of Professional Conduct and Client Care is available from www.reaa.govt.nz or by calling **0800 for REAA** (0800 367 7322).

What if my agent or someone related to them wants to buy the property?

If your agent, or anyone related to them, wants to buy your property, they must get your written consent to do this.

More information on this situation can be found in the Conflict of Interest Information Sheet, available from www.reaa.govt.nz or by calling **0800 for REAA** (0800 367 7322).

It is important to consult your lawyer throughout the buying and selling process.

Who pays the agent?

Real estate agents in New Zealand work on behalf of sellers and it is the sellers who pay the agents. An agent who is marketing a property on behalf of a seller cannot ask a buyer to pay for their services.

The agent is acting for the seller and does not have the same duty to a buyer as they do to the seller.

What is a buyers' agent?

Buyers' agents are common in some other countries. They are agents who are employed by buyers to locate properties and sometimes to negotiate purchases on the buyer's behalf. If you employ a buyers' agent you should still have a written agency agreement and will have to pay for their services.

More information on buyers' agents can be found in the Buyers' Agent Information Sheet, available from www.reaa.govt.nz or by calling **0800 for REAA** (0800 367 7322).

What if there's a problem?

If you are concerned about the behaviour of an agent, you should discuss any concerns you have with the agent or their manager. Agents are required to have in-house complaints resolution procedures.

If this does not work or if you do not wish to go through this process, you can contact the REAA.

The REAA has a number of ways it can help with your concerns. This includes sending the agent a compliance advice letter, arranging alternative dispute resolution or processing the matter as a complaint. When you contact the REAA they will help you identify the best way of dealing with your concern.

More information on how the REAA can help you can be found at www.reaa.govt.nz or by calling **0800 for REAA** (0800 367 7322).

You can get more information from ...

There are several places you can go for help and advice including:

- The Real Estate Agents Authority (REAA) at www.reaa.govt.nz or call 0800 for REAA (0800 367 7322). The REAA can provide information and assistance on a wide range of issues and is responsible for dealing with concerns about real estate agents.
- Your lawyer.
- Community Law Centres www.communitylaw.org.nz
- Citizens Advice Bureau www.cab.org.nz
- Ministry of Consumer Affairs www.consumeraffairs.govt.nz
- NZ Law Society Property Section www.propertylawyers.org.nz
- Consumer Build www.consumerbuild.org.nz

Real Estate Agents Authority

PO Box 25371, Wellington 6146

Phone: 0800 for REAA (0800 367 7322) or (04) 471 8930

Fax: 04 815 8468

Email: info@reaa.govt.nz

Website: www.reaa.govt.nz